

Innovative I/O Since 1977



Basic I/O Product Family

NOTICE:

This document contains two separate users manuals.

The first section should be used for the BIO4, BIO8, and BIO16 products.

The second section should be used for the BIO4AD, BIO8AD, and the BIO16AD products.

If you find that you have any questions with the setup or installation of any duTec product please feel free to call us:

Phone: 800-248-1632

or

E-mail: info@dutec.net

July 2004
First Revision



BASIC I/O
Hardware
Users
Manual



6979 Wales Road
Northwood, Ohio 43619

Phone: 419-666-4700
Toll Free: 800-248-1632
Fax: 419-666-4702

E-Mail: info@dutec.net
<http://www.dutec.net>

The Basic I/O	1 - 1
ANALOG INPUTS	1 - 2
DIGITAL INPUTS	1 - 4
DIGITAL OUTPUTS:	1 - 5
SYSTEM THROUGHPUT	1 - 6
COMMUNICATION PROTOCOL	1 - 8
Available I/O Modules	1 - 9
DIAGNOSTICS	1 - 10
PHYSICAL CHARACTERISTICS	1 - 10
PRODUCT TEST	1 - 11
Warranty:	1 - 11
MOUNTING	2 - 1
POWER WIRING	2 - 2
COMMUNICATING WITH THE BASIC I/O	2 - 3
Multidrop	2 - 4
Repeat	2 - 4
RS-422	2 - 5
RS-485	2 - 5
RS-485 Programming	2 - 6
COMMUNICATION WIRING	2 - 7
Network load V.S. Noise suppression	2 - 8
Network Bias Resistors	2 - 8
RS-422 HOST TO BASIC I/O	2 - 9
BASIC I/O TO BASIC I/O RS-422	2 - 10
RS-485 Host to BASIC I/O	2 - 11
BASIC I/O to BASIC I/O RS-485 (Multidrop only)	2 - 12
BASIC I/O Setup	2 - 13
Analog/ Digital	2 - 14
Addresses	2 - 14
Baud Rates	2 - 14
Protocol Handshake Types	2 - 15
Network Type Switch	2 - 16

Communication verification 2 - 18

Hardware error codes 2 - 19

Hardware watchdog 2 - 19

Sensor/ Actuator I/O wiring 2 - 19

 Analog Inputs: 2 - 20

 Analog Outputs: 2 - 22

 Digital Inputs: 2 - 23

 Digital Output Wiring 2 - 24

THE BASIC I/O:

BASIC I/Os are a family of small, industrial grade, remote data acquisition and control systems which exchange data with a Host computer via a serial communications link. Controlled by a wide range of software running on a Host computer, **Basic I/Os** are located near the sensors and actuators. The serial link eliminates the need for expensive and noise prone signal wiring between field sensors and actuators, and a central control room.

Each **BASIC I/O** system consists of one logic board connected to a 4, 8, or 16 position I/O module mounting rack. This combination is then field configurable to accept either analog or digital electrically isolated input or output modules which can interface to a wide variety of sensors and actuators.

BASIC I/O networks can service over 4000 analog and/or digital I/O lines in various combinations.

User selected serial communications between the Host and the first **BASIC I/O** can be RS-422 or RS-485. These communications links allow the units to operate up to 5000 feet apart. Baud rates from 300 to 38,400 are available.

The **BASIC I/O** instruction set core complies 100% with that of the OPTO- 22 Optomux TM . With this ASCII character, speak-only-when-spoken-to protocol, a Host transmits inquiry requests to the **BASIC I/O** to determine the status of its various process inputs. Similarly, the software in the Host computer makes control decisions and transmits instructions to the **BASIC I/O**, which in turn, makes the proper changes to its various outputs. Both the Host and its communications link are essential elements in this data acquisition and process control scheme.

Software for use with the **BASIC I/O** system can be obtained from a variety of sources. Nearly every third party SCADA software vendor has developed a driver which is compatible with this system. In addition, the communication protocol employed by the **BASIC I/O** product is a published ASCII printable standard. This makes developing your own software a simple matter. duTec also offers a software solution called **EASY I/O**. With this package, custom QuickBASIC source code is generated to fit the signals generated to fit the signals located on the **BASIC I/O**. Once configured, a simple data acquisition program is automatically generated. This sample can then be altered to fit the particular needs of the user.

A notable feature of the **BASIC I/O** is its ability to gather data and perform ranging and statistical operations on raw data before it is sent to the Host. The Host can thus spend less time manipulating data and more time gathering it. The following sections discuss the different signals the **BASIC I/O** can handle.

ANALOG INPUTS:

duTec analog input modules are 100% isolated and accept a wide range of voltages, currents, the outputs of thermocouples, RTDs, and 590 type temperature probes.

BASIC I/O instructions provide linearized thermocouple and RTD sensor data. Engineering unit conversion is performed by the host software, such as duTec’s EASYIO program generator.

The **BASIC I/O** samples individual analog inputs at the constant rate of samples per second. The effective sample rate per channel is determined by the total number of channels to be sampled.

Analog input instruction types are:

Input Value	Determines signal levels, with 12 bit (1 part in 4096) resolution
Offsets	Input values can be software offset or “Zeroed” with 12 bit (1 part in 4096) resolution over the module’s specified range.
Gain/Slope	The amplitude of input values can be software multiplied by factors ranging from 0.25 to 4.0.
Range Limits	The occurrence of input values falling out of user defined upper or lower limits can be flagged.
Minimums	The minimum level of input values can be captured.
Maximum	The maximum level of input values can be captured.
Averages	Can calculate average input amplitude for 1-65,535 samples.
Temperature	Provides linear temperature in C for thermocouples, RTD and type 590 temperature probes.

Thermocouple modules provide cold reference junction compensation.

ANALOG OUTPUTS:

Analog output modules are 100% isolated. These self-sourcing modules provide the voltage or current necessary to drive standard instrumentation loads. All are updated every 10 Ms, or 100 times per second.

Analog output instruction types are:

Level Value	Can set output levels, as a fraction of the module's full scale range, and are specified with 12 bit (1 part in 4096) resolution.
Waveforms	Can provide square, triangle, sawtooth or ramp waveforms, Maximum and Minimum amplitudes, as a fraction of the output module's full scale range, are specified with 12 bit (1 part in 4096) resolution. Waveform periods are specified from 0.1 to 6,553 seconds (about 109 minutes).

DIGITAL INPUTS:

Digital input modules detect the presence or absence of a field signal. Module types vary from AC to dry contact sense. Because the industry standard modules are optically isolated, the response time performance of digital input instructions can be limited by the delay in the input modules themselves. Some modules can have rise and fall times of up to 40 milliseconds.

Digital input instruction types are:

Read	Read the On or Off state of <i>all</i> inputs. This data is updated every 10 Milliseconds.
Edge Detection	Off-to- On and On-to-Off transitions can be detected within 1 millisecond of their occurrence. Action is only reported every 10 milliseconds.
Pulse Widths	BASIC I/Os can report pulse width measurements from .01 seconds to 46.6 hours. Minimum resolution is .01 seconds (Pulse widths up to 10.9 minutes). Either on or off pulses can be measured.
Pulse Counting	Pulses can be counted up to a total of 65,535. To be reliably counted, pulses must have a minimum On and Off time of 1 millisecond. Thus the maximum counting rate for a 50% duty cycle square wave is once every 2 milliseconds (500Hz).
Frequency	Direct frequency measurements can be made on digital inputs at rates of up to 500 Hz with a user specified time base of from .01 to 2.55 seconds.

DIGITAL OUTPUTS:

Digital output modules, commonly referred to as solid state relays, control external AC or DC power sources. A dry-contact (mechanical relay) with very low contact resistance is also available.

Digital output instruction types are:

- Set outputs Can set *individual* or *multiple* outputs On or Off.

- Pulse Generator Can generate 1 to 65,535, 50% duty cycle pulses whose equal On and Off periods can range from 0.01 to 2.55 seconds. Resolution can be reduced by a factor of 1-256 on a system wide basis to increase the maximum pulse width available.

- Modifiers:
- One Shot Can generate On or Off pulse durations of up to 10.9 minutes with a resolution of 0.01 seconds. Resolution can be reduced by a factor of 1-256 on a system wide basis increasing duration up to 46 hours. Re-triggering is available.

- Delayed Can generate delayed On or Off outputs after delaying up to 10.9 minutes with a resolution of 0.01 seconds. Resolution can be reduced by a factor of up 1-256 on a system wide basis increasing the delay before changing state up to 46.6 hours. Re-triggering is available.

- Square wave Can generate square waves with programmable On and Off periods. On and Off periods have a base range from 0.01 seconds to 10.9 minutes. Resolution can be reduced by a factor of 1-256 on a system wide basis increasing duration to 46.6 hours.

SYSTEM THROUGHPUT:

Input data throughput is the time from beginning of the first character of an input instruction to the end of the last character of the response. The processing time of the Host computer will affect the effective throughput.

Output Execution throughput is the time from the beginning of the first character of an instruction until the actual output changes. Because the instruction acknowledgment occurs before the outputs actually change state, the processing time of the host computer controlling output instructions can reduce the effective throughput. This is even possible at 38,400 baud to instruct the **BASIC I/O** to turn a digital output on and then immediately instruct it to turn back off so quickly that the module never actually gets activated.

Tables below show milliseconds per channel and channels per second for 1 and 16 I/O channel cases.

THROUGHPUT TABLES

Baud Rate	Input (Digital M)					Output (Digital J)				
	1 Channel		16 Channels			1 Channel		16 Channels		
	mSec/Chan	Chan/Sec	mSec/16 Ch	Chan/Sec		mSec/Chan	Chan/Sec	mSec/16 Ch	Chan/Sec	
300	501	2	501	32		379	3	379	42	
600	251	4	251	64		195	5	195	82	
1200	126	8	126	127		104	10	104	154	
2400	64	16	64	252		58	17	58	277	
4800	32	31	32	496		35	29	35	458	
9600	17	60	17	962		23	43	23	682	
19200	9	113	9	1816		18	56	18	902	
38400	5	204	5	3261		15	67	15	1076	

Baud Rate	Input (Analog L)					Output (Analog S)				
	1 Channel		16 Channels			1 Channel		16 Channels		
	mSec/Chan	Chan/Sec	mSec/16 Ch	Chan/Sec		mSec/Chan	Chan/Sec	mSec/16 Ch	Chan/Sec	
300	639	2	2639	6		484	1984	2	8	
600	323	3	1323	12		250	4	1000	16	
1200	164	6	664	24		134	7	509	31	
2400	85	12	335	48		75	13	263	61	
4800	46	22	71	94		46	22	140	114	
9600	26	39	88	181		32	32	78	204	
19200	16	63	47	339		24	41	48	335	
38400	11	91	27	602		21	48	32	494	

It should be noted that the values in the preceding throughput tables and the following equations reflect only the communications overhead and inherent processing delay of the **BASIC I/O** equipment. In practice, a significant amount of overhead will be devoted to other processing tasks such as screen updates, Data logging, etc... Typically these other tasks become the limiting factor in the “overall” throughput.

The equations below can be used for determining the hardware’s role in throughput for any number of channels. (**t** is in Milliseconds) Throughput for digital I/O is independent of the number of channels.

Digital Input Data (Digital M) Time for 1-16 channels:

$$t \text{ digital Input} = 1000 * ((150 / \text{Baud Rate}) + 0.001)$$

Digital Output Execution (Digital J) Time for 1-16 channels:

$$t \text{ digital Output} = 1000 * ((110 / \text{Baud Rate}) + 0.012)$$

Throughput for analog I/O varies with the number of channels, *n*.

Analog Input Data (Analog L) Time for *n* channels:

$$t \text{ analog Input} = 1000 * (((150 + 40 * n) / \text{Baud Rate}) + 0.006)$$

Analog Output Execution (Analog S) Time for *n* channels:

$$t \text{ analog output} = 1000 * (((110 + 30 * n) / \text{Baud Rate}) + 0.017)$$

For determining the throughput for systems with a mixture of analog and digital data inputs and the execution of analog and digital outputs, it is necessary to determine the time for each instruction using these equations. The sum of these, **t**, In milliseconds, is the time required to provide the service required by all instructions.

$$t = t \text{ digital Input} + t \text{ digital Output} + t \text{ analog Input} + t \text{ analog Output}$$

Dividing this sum into 1000 (milliseconds) yields the number of cycles per second.

$$\text{Complete cycles/ Sec} = 1000 / t$$

COMMUNICATION PROTOCOL:

The **BASIC I/O** Communication Protocol is 100% compatible with the Opto-22 Optomux™ protocol. This ASCII printable serial protocol uses a “speak-only-when-spoken-to” format where only the host can *initiate* an information exchange. Each **BASIC I/O** unit installed in a network has a unique address. This address is embedded in the instruction generated by the host computer. Every **BASIC I/O** chassis receives the instruction but only the unit which is set to the address found in that instruction will respond. Every string of data whose length is greater than one character is followed by a checksum to ensure data integrity. This protocol also provides an instruction verification mode for further data transmission reliability.

As a result of the specific nature of the **BASIC I/O** communications protocol, the RS-422 or RS-485 network can be shared with other devices whose protocol is similar.

A knowledge of serial communications, hexadecimal to decimal conversion, and string data manipulation is required to compose custom user generated Host software. DuTec's **EASY I/O** software is designed to minimize these obstacles.

Available I/O Modules

ANALOG INPUTS, 12 BIT		ANALOG OUTPUTS, 12 BIT	
Frequency	Voltage		Voltage
IF10K-B	Input 300Hz -10KHz	OV1	Output 0-1V, self-sourcing
IF2.5K-L	Input 0-2.5KHz	OV5	Output 0-5V, self-sourcing
IF5K-I	Input 0-5KHz	OV10	Output 0-10V, self-sourcing
IF10K-L	Input 0-10KHz		
	Voltage		Current
IV25M	Input 0-25mV	OI420	Output 4-20mA, self-sourcing To 275 Ohm load.
IV50M	Input 0-50mV		
IV100M	Input 0-100mV		
IV1	Input 0-1V		DIGITAL INPUTS
IV5	Input 0-5V	AC	
IV5B	Input Bipolar +/-5V	IAC5	Input 90-140Vac
IV10	Input 0-10V	IAC5A	Input 180-280Vac
IV10B	Input Bipolar +/-10V	DC	
IVAC	Input 28-140Vac	IDC5D	Input 3-32Vdc Fast, >500Hz
IVAC-A	Input 56-280Vac	IDC5S*	Input Dry Contact Sense Built-in Isolated Voltage Source
	Current	IDC5NP	Input 10-32 Vdc, 15-32Vac Non-Polarized
II420	Input 4-20mAadc		
IIAC5	Input 0-5Aac		
	Thermocouple		DIGITAL OUTPUTS
ITCE	Type E 0 To 435 C	AC	
ITCJ	Type J 0 To 700 C	OAC5	Output 12-140Vac, 3.5A
ITCJ-1	Type J -80 To 750 C	OAC5A	Output 24-280Vac, N.C.(Normally Closed)
ITCK	Type K -100 To 924 C	OAC5J	Output 20-280Vac, 6.0A
ITCK-1	Type K -110 To 1250 C		
ITCR	Type R 0 To 960 C		DC
ITCR-1	Type R 0 To 1760 C	ODC5	Output 5-60Vdc, 3.5A
ITCS	Type S 0 To 1034 C	ODC5A	Output 4-200Vdc, 1.0A
ITCS-1	Type S 0 To 1760 C	ODC5R	Electro-Mechanical 0.5A Relay Form A, Normally Open (NO)
ITCT	Type T -200 To 224 C		
ITCT-1	Type T -120 To 400 C		SPECIAL PURPOSE
ITCT-2	Type T 0 To 150 C	IDC5Z*	Input +/-200mV, 0-10KHz Digital**
	RTD	SPS-1*	Sensor Power Supply 18-24 Vdc, 30mA
ITR10	10 Ohm Cu -55 To 150 C	TI01	Digital Input/ Output Test Module with Field Switch and LED
ITR100	100 Ohm Pt -55 To 350 C		SUPPORT PRODUCTS
ITR100-1	100 Ohm Pt 0 To 100 C		Fuses
	Type 590 Temperature Sensor	FM-06	Fuse Assembly 0.062A
ITP590	-188.4 To 150 C	FM-1	Fuse assembly, 1.0A
ITP590-1	-50.0 To 150 C	FM-3	Fuse assembly , 3.0A
		FM-5	Fuse assembly, 5.0A

* When selecting a power supply for the system assume 25mA for standard digital modules and 100 mA for marked with an *** The IDC5Z module is used for low-level signals and will pass signals at the rate of 10KHz The **BASIC I/O** however, is limited to signals up to 500Hz.

DIAGNOSTICS:

To confirm internal operations and communications link integrity, a set of built-in diagnostics test key system functions each time power is applied. Diagnostics reduce both installation debugging and operation troubleshooting.

A hardware watchdog timer insures safe shutdown in the event of processor or software failures by turning all outputs OFF. Normally ON modules are available for those loads that must remain ON.

PHYSICAL CHARACTERISTICS

Power Requirements

- Voltage: 5.0-5.4Vdc
- Current: 250mA +25mA Per digital module.

Note that the current draw of some specialized digital modules Such as the IDC5S or the ODC5R, can be substantially larger Than 25mA. Consult the specific module data sheet for this Value when sizing power supplies.

- Operating Temp. 0 C to 60 C Contact factory for other operating temp Ranges
- Humidity 95% non-condensing
- Weight 22 oz. Max (BIO16) Not including modules.

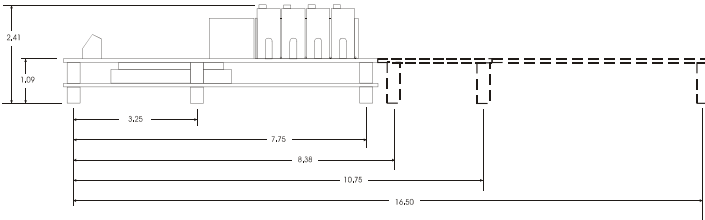
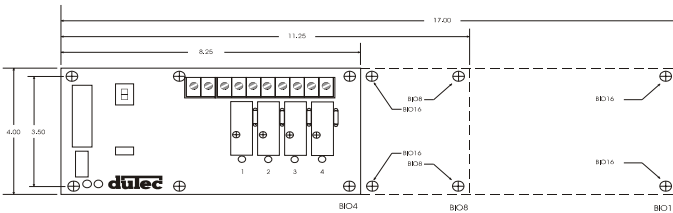

BASIC I/Os are ready to install, only dc power, communication and sensor or actuator wiring is required

PRODUCT TEST

Every **BASIC I/O** is burned-in at 70 °C while operating in a network for a period of 24 hours prior to shipment.

Every analog I/O module is operated and tested while it's ambient operating temperature is cycled over the specified operating range of 0°C to 60°C for a period of 24 hours.

BASIC I/O Models:

- BIO4 4 Position **BASIC I/O** Unit Includes SLB Logic Board and SMB4 Module board less modules and power supply.

- BIO8 8 Position **BASIC I/O** Unit Includes SLB Logic board and SMB8 module board less modules and power supply.

- BIO16 16 Position **BASIC I/O** Unit Includes SLB logic board and SMB16 module board less modules and power supply.

Warranty: duTec warrants its products to be free of defects in materials and workmanship for a period of two (2) years from date of shipment. DuTec may, at its option repair or replace all materials found to be defective. All repair or replacement must be performed by duTec personnel. Any parts determined by duTec to be defective as a result of abuse, attempts to repair, or misuse by the customer will be repaired at the expense of the customer.

NOTES

Setup & Installation 2

MOUNTING:

BASIC I/Os come in 4, 8, and 16 channel versions. Figure 2-1 below shows the footprint of each **BASIC I/O**. Using corner holes, the unit can be mounted with 4- #6 or #8 round head or pan head screws. The BIO16 version has two additional mounting holes located near the center of the board as well. Hole locations in relation to the overall dimensions for each are shown below. Since the same **BASIC I/O** boards are used for digital or analog applications, the same mounting dimensions and panel space are used for both.

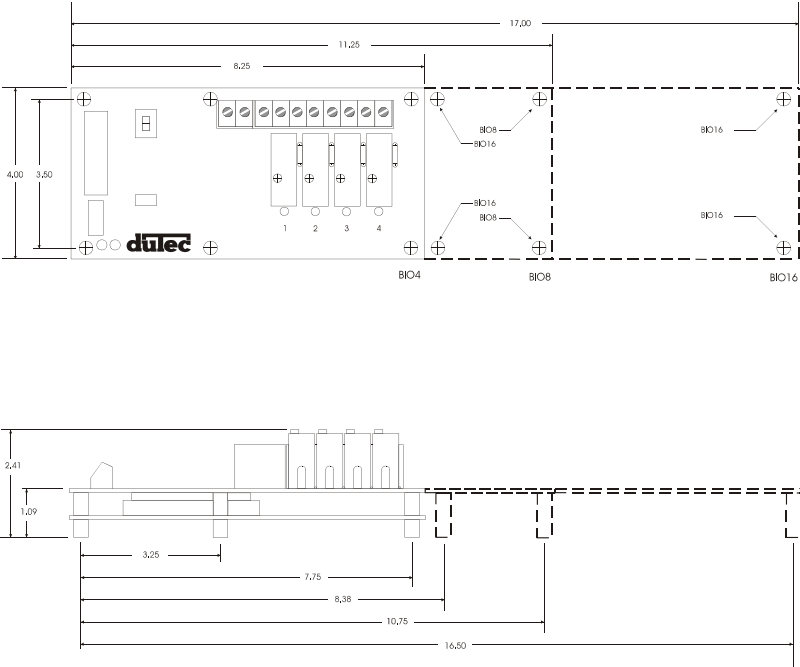
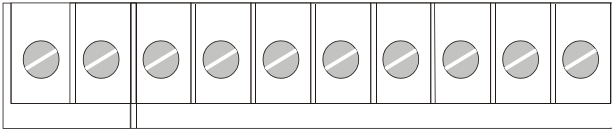

FIGURE 2-1 BASIC I/O FOOTPRINT

POWER WIRING:

Power connections are made at the 2 position terminal block located on the module board marked +5V and GND. No. 8 captive wire clamps accept 10-16 AWG wire or spade lugs.

+5V GND



Power wiring conventions:

- + of the power source to the +5V terminal
- of the power source to the terminal marked GND

Power requirements

Voltage: 5.0- 5.4Vdc

Current: 250 mA + 25mA per digital module or 250 + 200mA per analog module.

Note that the current draw of some specialized digital modules such as the IDC5S or the IDC5Z, can be substantially larger than 25 mA. Consult the specific module data sheet for this value when sizing power supplies.

Practices: In general it is good practice to reserve the +5Vdc power supply exclusively for the task of powering one or more **BASIC I/O** units. As with any microprocessor based equipment, reasonably clean power is required for reliable operation. Sharing power with other devices such as field signal transducers and contact excitation should be avoided.

COMMUNICATING WITH THE BASIC I/O:

The **BASIC I/O** is designed to serve as an intelligent I/O front end for a Host computer (Typically a P.C.). The host and **BASIC I/O** communicate over a serial link. This interchange is *half-duplex* in nature; that is to say the host and **BASIC I/O** will never be transmitting at the exact same time. Further, the communications protocol is considered “speak-only-when-spoken-to”; the Host must poll the **BASIC I/O** whenever it needs fresh data. This polling is accomplished when the host sends an instruction to the **BASIC I/O**. The **BASIC I/O** will then generate a reply. Each valid instruction will illicit a corresponding response. The integrity of this communication is verified using message content checksums.

The serial communication is a form of ASCII printable characters and makes heavy use of the hexadecimal numbering system. The format of the ASCII characters used is: One start bit, eight data bits, one stop bit, and no parity.

Setup & Installation 2

BASIC I/Os can be networked together to obtain up to 4096 I/O points of data. These serial networks can be either multidrop or repeat.

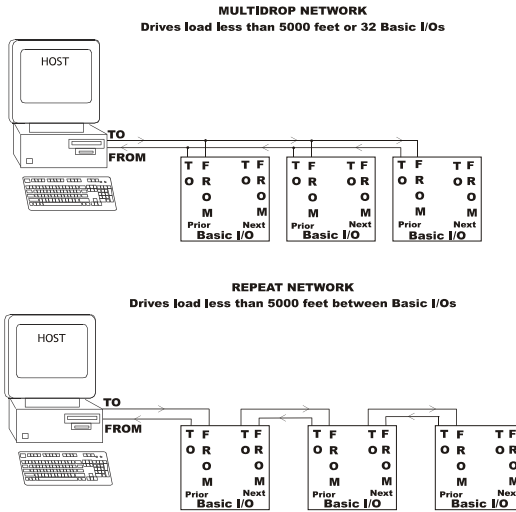

Figure 2-3 Multidrop V.S. Repeat networks

Multidrop:

Multidrop networks can be up to 5000 ft long end-to-end.

Each station is passively located on the network and represents one “Drop” or load to the host communication driver.

A multidrop network will tolerate loss of power to any one station without effecting the rest of the network..

RS-485 can only be multidrop

Signal boost may be necessary depending on line conditions and number of drops.

Repeat:

Repeat networks can be as long as 5000 ft between each unit.

Each station plays an active role in communications to other units. If power is removed from a unit in a repeat network, communications to units “downstream” from it will be lost as well.

Setup & Installation 2

The serial communications link between a Host computer and a network of **BASIC I/Os** is made up of either a single (RS-485 half-duplex) or Dual (RS-422 full duplex) shielded twisted pair (s) of wires whose shields are connected to a signal common conductor. This communications link should in turn have an overall shield which is isolated from the signals (including signal ground) and connected to earth or chassis ground at one location. The most common cause of difficulty experienced by customers in the field is improperly installed communications wiring.

RS-422:

Advantages:

- Easier to implement in software since host driver need not be controlled.
- Can be either Multidrop or Repeat
- No turn-around delay required.

Disadvantages:

- Requires five conductor wire instead of three

RS-485:

Advantages:

- Needs only 3 wire conductor

Disadvantages:

- Host 485 driver control must be implemented requiring tricky serial port manipulations
- Can only be Multidrop
- Usually requires turn around delay implementation.

RS-485 Programming:

The **BASIC I/O** will work equally well when connected to either RS-422 or RS-485. However special host programming considerations may be necessary when implementing an RS-485 network. Unlike RS-422 where both the *transmit and Receive* signals have their own differential pair of conductors, RS-485 utilizes only one differential pair. The single pair of conductors is used bidirectionally and handles both *transmit and receive* signals. In order for this to be possible, the transmitter for each device on this type of network must be enabled and disabled whenever a message is to be sent. The transmitter for the **BASIC I/O** is designed to handle this control automatically. However, the transmitter control for most popular RS-485 cards that are installed in the Host computer must be controlled by the user program. This control is not straight forward and may impact the overall system throughput with inherent delay periods. The following is a typical instruction/ response transaction between a host computer and a **BASIC I/O** using **RS-485**.

- 1) The Host computer enables its RS-485 transmitter (usually via the RTS line)
- 2) The Host then sends an instruction to the **BASIC I/O** in the form of an ASCII printable string.
- 3) Once the Host determines that the string has been completely sent, the RS-485 transmitter is disabled.
- 4) Every **BASIC I/O** on the network receives the instruction and begin to decode it. That particular **BASIC I/O** addressed begins to construct a response.
- 5) Once the carriage return is of the instruction is received, the **BASIC I/O** begins to transmit a response.
- 6) The Host receives the response and takes the appropriate action.

This interaction is heavily dependant on asynchronous timing. Usually, the Host software has no real means of determining that the instruction has been completely sent. This means that the program must calculate the

Setup & Installation 2

approximate time necessary to transmit the entire instruction before the RS-485 driver is disabled. Since the **BASIC I/O** can respond very quickly to the instruction, the Host must disable the driver as soon as possible in order to receive the **BASIC I/Os** response. RS-485 communications can be tricky at best and should be seriously considered before being adopted. Third party software users should make sure that the package they have chosen supports the particular RS-485 communications card to be used.

COMMUNICATION WIRING:

The Host to first **BASIC I/O** can be RS-422 or RS-485. Most Host computers come equipped with an RS-232 serial port. A choice must be made to either equip the host with an RS-422 or RS-485 card or to use an external RS-232 to RS-422/ 485 converter.

For ranges less than 5000 feet, both RS-422 and RS-485 networks can operate in multidrop mode. For ranges greater than 5000 feet, RS-422 (NOT RS-485) networks can operate in repeater mode. In this mode, the distance between individual units can be up to 5000 feet. The trade-off for using the repeat mode is that the powering down of any single unit disables communications with all units further “downstream” from the host.

A network of **BASIC I/O's** must be made up of units which are configured as either all multidrop or all repeat.

Network load V.S. Noise suppression:

In order to improve RS-485 Bus noise immunity, particularly under tri-state conditions, a pair of “Network Bias Resistors” have been installed in each **BASIC I/O** unit. This design feature has been implemented in order to satisfy the majority of our customers. If it is necessary to multidrop more than eight **BASIC I/O** units (but ultimately less than thirty-two devices), It will be necessary to remove these network bias resistors so as to not exceed the maximum bus loading. However, in order to retain noise immunity, the network bias resistors should remain installed in at least one **BASIC I/O** on the network. Figure 2-4 below shows the location of the four network bias resistors.

- R34 is the 1.5k from prior +bias resistor**
- R35 is the 1.5k from prior - bias resistor**
- R36 is the 1.5k from next + bias resistor**
- R37 is the 1.5k from next - bias resistor**

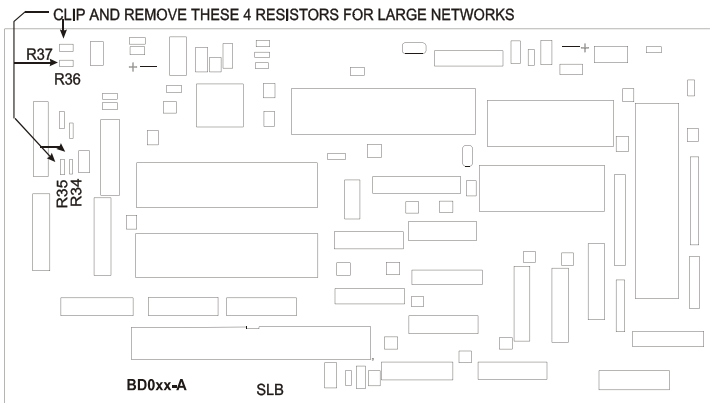

Figure 2-4 Network Bias Resistor Locations

RS-422 HOST TO BASIC I/O:

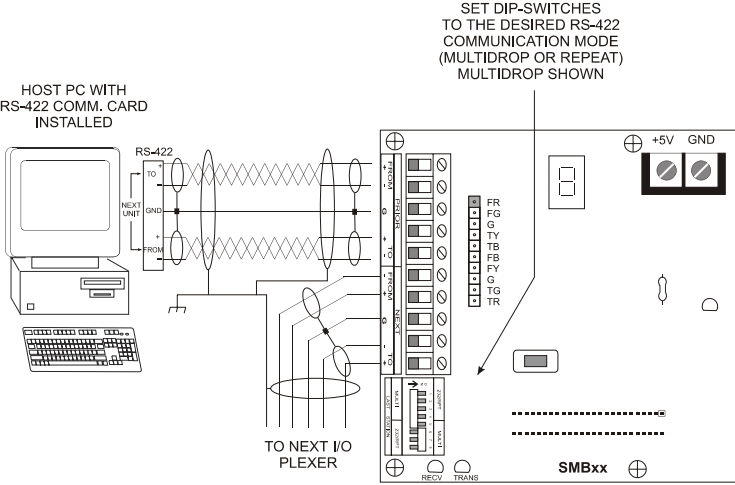

Figure 2-5 RS-422 Host to BASIC I/O wiring

Figure 2-5 shows two individually shielded twisted pairs of AWG 24. Each pair has a ground wire connected to its shield. These drain wires are then connected to the signal grounds at each unit. A Separate shield encases the entire cable. The drain wire for this over-all shield is tied to earth ground at one location. An example of acceptable wire for this application would be Belden 8162. In a perfect world with no electrical noise and equal ground potentials everywhere, the ground connection is not required. However, omitting this signal ground in industrial applications can lead to costly debugging.

These connections are made by placing a 1/4 inch stripped wire into the openings of the wire clamp terminal block and tightening the screw. This terminal block will accept gauges from 14 to 30AWG.

An alternate means for network connection is to use the 10 pin male connector located behind the clamp terminal block. This connector mates with Molex shell number 50-57-9005, and uses pins number 16-02-0103.

In addition to the Host-To-BASIC I/O wiring, the installer should confirm that the network type switches are set in the correct position: Multidrop, Repeater, or Last Unit.

BASIC I/O TO BASIC I/O RS-422 MULTIDROP OR REPEATER**Figure 2-6 RS-422 BASIC I/O-To-BASIC I/O multidrop**

Figure 2-6 shows two individually shielded twisted pairs of AWG24. Each pair has a drain wire connected to its shield. These drain wires are then connected to the signal grounds at each unit. A separate shield encases the entire cable. The drain wire for the over-all shield is tied to earth ground at one end. An example of acceptable wire for this application would be Belden 8162. In a perfect world with no electrical noise and equal ground potentials everywhere, the ground connection is not required. Omitting this signal ground in industrial applications can lead to unstable operation and costly debugging.

These connections are made by placing a 1/4 inch stripped wire into the openings of the wire clamp terminal block and tightening the screw. This terminal block will accept gauges from 14 to 30 AWG.

An alternate means of network connection is to use the ten pin male connector located behind the clamp terminal block. This connector mates with Molex shell number 50-57-9005, and uses pins 16-02-0103.

In addition to the **BASIC I/O to BASIC I/O** wiring, the installer should confirm that the network type switches are set in their correct position: Multidrop, Repeater, or Last unit.

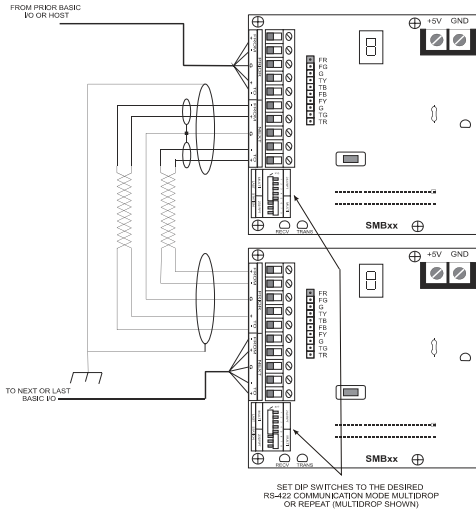
NOTE: The number of **BASIC I/Os** that can be networked in a multidrop configuration before a signal amplifier (An external repeater) is needed depends greatly on external factors. Repeater networks are unlimited.

BASIC I/O to BASIC I/O RS-485 (Multidrop only):

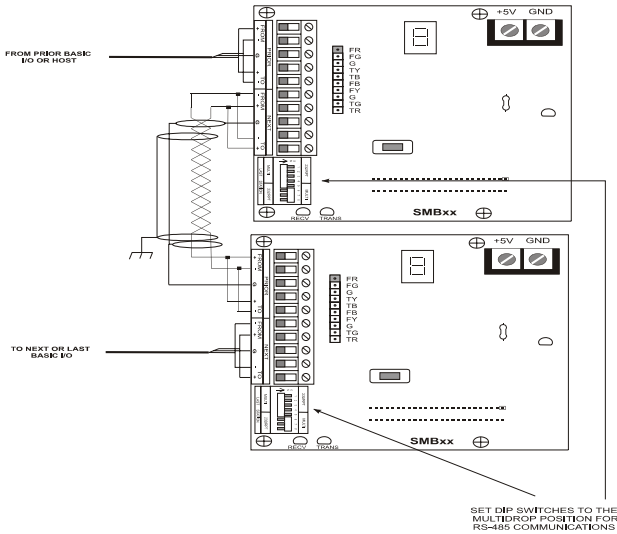

Figure 2-8 RS-485 BASIC I/O to BASIC I/O Multidrop

Figure 2.8 shows one individually shielded twisted pair of AWG 24. Each pair has a ground wire connected to its shield. These drain wires are then connected to the signal grounds at each unit. A Separate shield encases the entire cable. The drain wire for this over-all shield is tied to earth ground at one location. In a perfect world with no electrical noise and equal ground potentials everywhere, the ground connection is not required. However, omitting this signal ground in industrial applications can lead to costly debugging.

These connections are made by placing a 1/4 inch stripped wire into the openings of the wire clamp terminal block and tightening the screw. This terminal block will accept gauges from 14 to 30AWG.

An alternate means for network connection is to use the 10 pin male connector located behind the clamp terminal block. This connector mates with Molex shell number 50-57-9005, and uses pins number 16-02-0103.

In addition to the Host-To-BASIC I/O wiring, the installer should confirm that the network type switches are set in the correct position: Multidrop, Repeater, or Last Unit.

NOTE: The number of BASIC I/Os that can be networked in a multidrop configuration before a signal amplifier (An external repeater) is needed depends greatly on external factors. Repeater networks are unlimited.

BASIC I/O setup:

BASIC I/O setup is accomplished with a sequential display and pushbutton. Below is a diagram of the location of these components.:

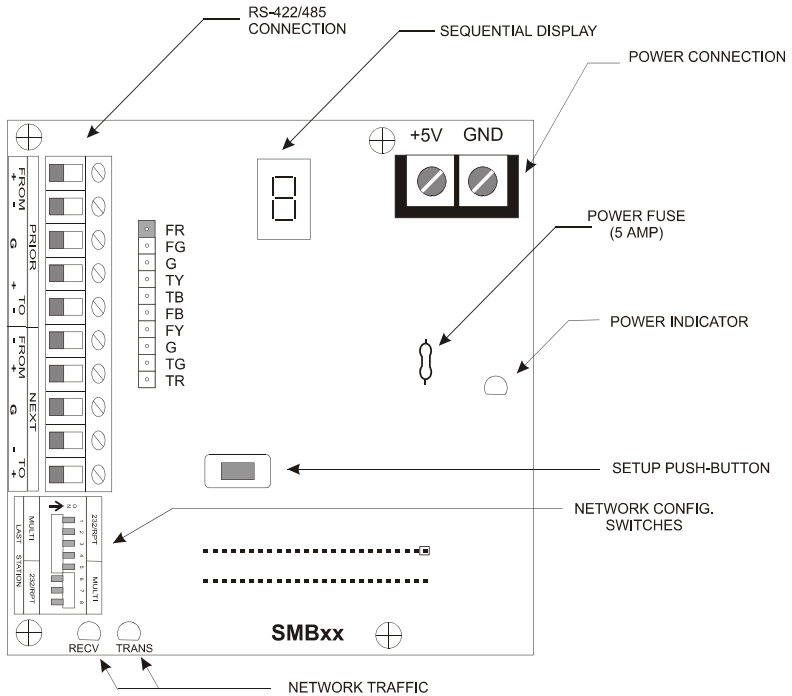

Figure 2-9 BASIC I/O Connectors, Switches and Indicators.

Unit type (digital or analog), Unit address, baud rate, and 2 or 4 pass protocols are all pushbutton configurable and appear on the sequential display. After line power application and the performance of system diagnostics, there is a five second period during which these setup values any be changed. Changed values are automatically saved on a non-volatile EEPROM.

Analog/ Digital:

The **BASIC I/O** system must be configured to accept either Analog or Digital I/O modules. The current I/O type is displayed on the sequential display and is indicated by the character following the "U". The unit will display a"1" if the unit is configured as digital and a"2" if the unit is analog. This value is stored in EEPROM and need only be set once. The factory default I/O type is digital. Changing the **BASIC I/O** I/O type is explained after the description of addresses, baud rates, hand-shaking, and network types.

Addresses:

Each host instruction includes an address made up of two hexadecimal characters (00h to Ffh). This address determines which chassis is to execute the instruction being sent; all other chassis are to ignore the instruction. Each **BASIC I/O** chassis has a unique address. The factory default address is "00". Changing the **BASIC I/O** address is explained after the description of baud rates, hand-shaking, and network types.

Baud Rates:

Any *One* of the standard baud rates of 300, 600, 1200, 2400, 4800, 9600, 19200, or 38400 can be used for the serial network communications. The sequential display indicates the letter H followed by the baud rate divided by 100. **BASIC I/Os** are shipped at 9600 baud; the sequential display indicates H096. Changing the **BASIC I/O** baud rate is explained after the description of hand-shaking and network types.

Protocol Handshake Types:

Two protocol handshake types are available, 2 pass and 4 pass.

2 Pass: The host transmits an instruction to a **BASIC I/O**.

If the instruction is correctly received (i.e. valid address, instruction type and correct checksum) the **BASIC I/O** executes the instruction and returns the letter "A" and a cr or, where data is to be returned, the letter "A", then the data, followed by a two character checksum ending with a cr.

4 Pass: The host transmits an instruction to a **BASIC I/O**.

If the instruction is correctly received (i.e. valid address, but not necessarily the correct instruction type nor checksum), the **BASIC I/O** returns an "A" followed by the Echo of the instruction and does *not* execute it.

If the host then transmits an E, the instruction is executed in the same manner as the 2 pass. If the Hos transmits *any* other character to *any* unit on the network, the instruction is disregarded.

The sequential display indicates the letter P followed by 2 or 4. **BASIC I/Os** are shipped in 2 pass mode; the sequential display indicates P2. The actual setting of the handshake protocol type is detailed following network type switch.

Network Type Switch:

Based upon the selected network configuration, each **BASIC I/O** must be setup before communications can begin. This is done with the network switches shown below. The three basic communication connections for individual **BASIC I/O**s are:

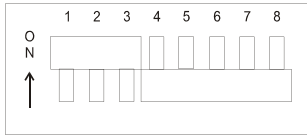
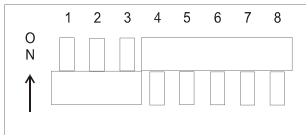
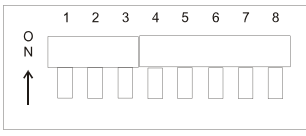
<p>L1 Repeater</p> <p>Used in RS-422 networks to extend range to 5000 feet between units</p>	
<p>L2 Multidrop</p> <p>Used in RS-422 or RS-485 networks. Provides a total network range of 5000 feet.</p>	
<p>L3 Last Unit</p> <p>Must be used in RS-422 and RS-485 networks for the unit most distant from the host</p>	

If there is only one **BASIC I/O** in a network it is designated L3. For the network layout, the sequential display indicates the letter “L” followed by “1”, “2”, or “3”. As shipped, **BASIC I/O**s are setup as “L3”, Last Unit. This parameter is not changed by push button but is displayed as “L1”, “L2”, or “L3” after the dip switches have been set and the unit has undergone a power cycle. When the unit is configured for “L3” a network termination resistor is placed across the differential receiver. A value of 150 Ohms was selected to suit most applications. A detailed analysis of transmission line effects (reflections), which is beyond the scope of this document, would be necessary to select the ideal termination resistor for any given application. If the customer wishes to terminate the communication bus externally (at the terminal block location) then it is imperative that no **BASIC I/O** network switches be set to “L3”. EIA standards dictate that the total bus impedance for RS-485 can be no less than 60 Ohms.

Setup via Pushbutton:

The pushbutton, located on the logic board (see figure 2-9) is used to configure the unit address, baudrate, and network pass type.

During the diagnostic test period following the application of power, the sequential display shows “GO GO GO GO GO GO≡ “ *Pumping* the pushbutton once while the≡ appears, places the unit in the *setup mode*.

The **BASIC I/O** then flashes: **U100 H096 P2**

The underlined values represent setup parameters that can be changed.

The digit following the U represents whether the unit is analog/digital where 1 indicates digital and 2 indicates analog. The initial configuration is default 1 or digital..

The next two digits indicate the unit address; initially set to address 00h

The three digits after H is the baudrate divided by 100; initially set for 9600 baud.

The 1 digit after P is the handshake protocol type; initially set for 2 pass

The value of each setup character can be changed, as they appear in sequence, by pumping the pushbutton. As the button is pressed, the display will cycle through the possible values for each character. When the desired character is displayed simply wait for a brief period for the display to blank. The next character position to be changed will then appear on the display.

The display continues to cycle through until there is a full cycle with no changes. The **BASIC I/O** then stores all values in EEPROM for automatic use following subsequent power cycles. The unit is now in the operational mode and the sequential display becomes:

U1=00 H096 L3 P2

The underlined values represent setup parameters that can be changed

If any desired changes were not completed, line power can be recycled and the setup via pushbutton can be repeated if necessary.

Communication verification:

Network Debugging:

Most startup problems are related to the communication link. The installer is urged, after both the communications wiring and configuration have been completed, to test the network *before* installing I/O modules.

To test the serial communications link, the host transmits the abbreviated test instruction:

>NN~~A~~?? For each **BASIC I/O** address on the network, where NN is the address of each **BASIC I/O**. This appears on the Sequential display after the U1 or U2.

Both the Host and the **BASIC I/O** under test are used to verify wiring, system configuration and operation. If the addressed unit returns an A, acknowledgment, the communications link is operational and the selected address is correctly configured. *All* addresses on the network should be tested by the same means.

If the A acknowledgment is not returned, the behavior of the two network traffic displays should be investigated.

The left LED (RECV) should blink on every **BASIC I/O** when the host transmits an instruction. This should occur regardless of baud rate. If there is no indication of network traffic, the failure can be anywhere from the host's hardware or software to the **BASIC I/O**. Generally the failure of the receive light to blink when the host transmits can be attributed to faulty communications wiring. Locating the cause of the failure should start from the host.

The right LED (marked TRANS) blinks only when the addressed **BASIC I/O** responds to a host instruction. If the Trans LED blinks, but the host does not receive an A acknowledgment, the return circuit is suspect.

If an instruction is sent to the **BASIC I/O** and the RECV LED flashes but the TRANS LED does not flash in response, first verify that the Baud rate and Unit address are correct. If both are correct, disconnect the wires attached to the "TO PRIOR + and -" terminals. And resend the command. If the **BASIC I/O** Trans LED still does not flash in response to a host request, contact duTec for service. If the **BASIC I/O** Trans LED does flash in response to a host instruction, the return circuit from the **BASIC I/O** to the host should be verified. If this test is not successful the host's receiving hardware should be tested.

Hardware error codes:

When the **BASIC I/O** is initially powered up, it goes through an internal self test. If any of the self-diagnostics fail, the unit will report an appropriate error code on the sequential display and halt.

Error Code 3

If a solid 3 appears in the sequential display, recycle power without touching the pushbutton. This does not mean that there is a problem, it means it is in factory test mode. Recycle power without holding down the pushbutton.

Other error codes

If 0, 1, 2, 4,6, or 7 appear on the display permanently there is a problem. Recycle power. If that does not resolve the error condition, please call duTec at 800-248-1632.

Hardware watchdog

The hardware watchdog acts automatically in the event of a hardware or firmware failure and responds within one second. The hardware watchdog turns all outputs off, and resets the **BASIC I/O**. Do not confuse this with the programmable communication watchdog delay instruction.

Fuses

A plug-in 5 amp, UL rated, fuse is installed between the minus field terminal and the I/O module. These fuses are generally only needed to protect output modules. Optional fuse values are available for special output protection requirements. Fuses are installed in sockets located on the module board next to the module. Thermocouples and RTD inputs do not utilize their terminal block and therefore do not make use of the fuse.

Sensor/ Actuator I/O wiring

Analog or digital modules can be placed at any module position. However it is good practice for noise pickup, debugging and maintenance reasons to group and wire similar module types together. For minimum crosstalk between input and output wiring, input modules should be located at one end followed by output modules.

Modules should **NEVER** Be installed or removed while power is applied to the **BASIC I/O**. Following insertion in their respective sockets, modules should be secured with the captive screw.

Analog Inputs:

Note: analog modules normally run hot to the touch.

Correct polarity connections are essential to proper operation of all the analog inputs. Connections to terminals marked with a + must be more positive than the terminals marked with a -. Thermocouples and RTDs are connected directly to modules with special connectors which insure correct polarity.

Analog input module status indicators are On dimly, when input modules are installed, wired correctly, and their input signal is within the module's valid range. If these conditions are not met, the indicator light may be on brightly, off or may flicker.

The wiring and operation of analog input modules can be verified by the host issuing a Configure as Input instruction, setup H, followed by a read input value instruction, Analog L. See the software protocol manual or quick reference card for instruction details.

Figure 2-10, figure 2-11, and figure 2-12 show the wiring for various types of analog inputs. With the exception of thermocouples and RTD modules, connections are made via the black terminal strip. In the case of thermocouples and RTDs mating connectors are included. There must be nothing connected to the screw terminals corresponding to these module positions. The source of analog input voltage or current is external to the **BASIC I/O** with the exception of ITP590, ITR10, ITR100, and ITR100-1.

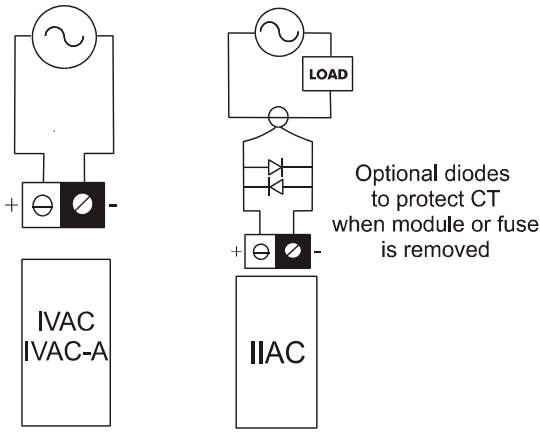

Figure 2-10 AC Current and Voltage Wiring.

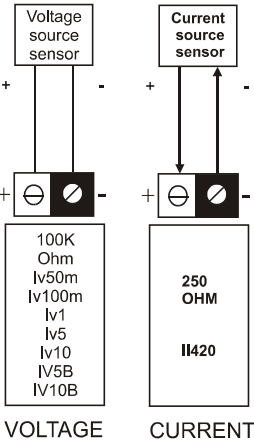

Figure 2-11 Analog Voltage and Current input Wiring

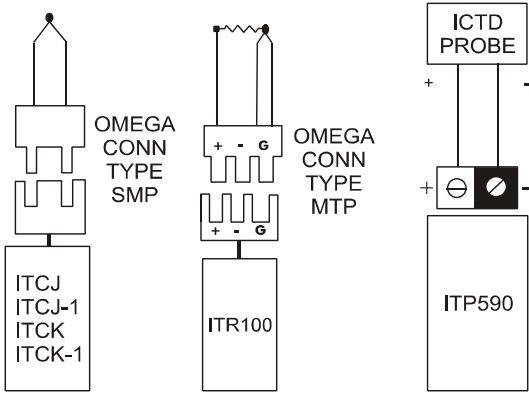

Figure 2-12 Temperature Input Wiring

Analog outputs:

Modules should NEVER be installed or removed while power is applied to the **BASIC I/O**. Following insertion in their respective sockets, modules should be secured with their captive screw. Correct polarity is essential to proper operation.

Note: Analog modules run hot to the touch.

Both voltage and current output modules provide their own isolated power output. This eliminates the need for external power supplies and insures electrical isolation between each output. This also makes it possible to wire voltage outputs in series to obtain larger voltage swings.

The wiring of analog output modules can be verified by the host issuing a configure as outputs instruction, Setup 1, followed by a set output level analog J instruction. See [software protocol manual](#), or Quick reference card for instruction details.

Module status indicators for analog outputs blink briefly as outputs are updated. It should be noted that the status indicator only follows the logic instruction to the modules and does not show that the module or its fuse is present. Outputs can only be verified by observing the output device or by a multimeter or oscilloscope measurement.

OI420 analog output modules provide the current into loops with total resistance less than 275 ohms. If the loop resistance exceeds 275 ohms, an external power supply must be added to the loop as shown in figure 2-13 correct polarity is essential. The added voltage should be a nominal 1 volt for each added 50 ohms of loop resistance in excess of 275 Ohms. The total added voltage can be up to 5 volts larger than the nominal calculation without damage. The voltage regulation of the added supply can be as poor as +/-10% without affecting accuracy.

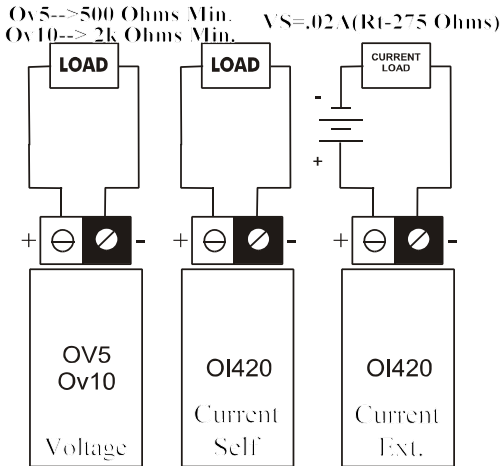

Figure 2-13 Analog Voltage and Current Output Wiring

Digital Inputs:

Modules should never be installed while power is applied to the **BASIC I/O**.

With the exception of IDC5S digital input modules, input sensing current comes from a source external to the **BASIC I/O**. IDC5S input modules provide their own current for sensing contact closures. They can be **DESTROYED** if an external source is used.

The IDC5 and IDC5D input modules are polarity sensitive and operate only when the + terminal is more positive with respect to the - terminal. Polarity does not affect the performance of the IAC5, IAC5A, or the IDC5S input modules.

Because the field side of input modules are totally isolated from each other, like polarities can be wired common to make use of a single power supply.

The wiring and operation of digital input modules can be verified by closing the individual input sensing contacts and observing the changes on the module status indicators. They are on when the module circuit is energized. Their wiring can also be verified at the host by issuing a configure as input instruction, setup H, followed by a read all modules instruction, digital M. See [software protocol manual](#), or quick reference card for instruction details.

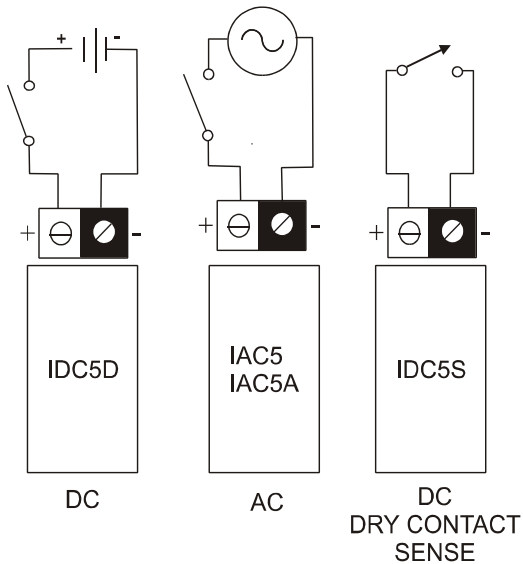

Figure 2-14 Digital Input Wiring

Digital Outputs:

Modules should **NEVER** be installed or removed while power is applied to the **BASIC I/O**. The power for ODC5, ODC5A, OAC5, and OAC5A digital output modules comes from a source external to the **BASIC I/O**.

Because they contain a protective reverse diode, the ODC5 and ODC5A output modules are polarity sensitive and operate correctly only when the + terminal is positive with respect to the - terminal. A DC digital output module connected backwards conducts current through its protective diode and therefore cannot be controlled.

Polarity does not affect the performance of the OAC5 and OAC5A Digital output modules. Because the field sides of output modules are totally isolated from each other, like polarities can be wired common to make use of a single power supply.

The wiring of digital output modules can be verified by the host issuing a configure as output instruction, control 1, followed by an output on/ off digital J, instruction. See [software protocol manual](#) or quick reference card for instruction details.

The module status indicator should follow the instruction. It should be noted that the status indicator only follows the logic instruction to the modules and does not show that the module, its fuse, or that external power is present. Outputs can only be verified by observing the device or by a multimeter or oscilloscope measurement.

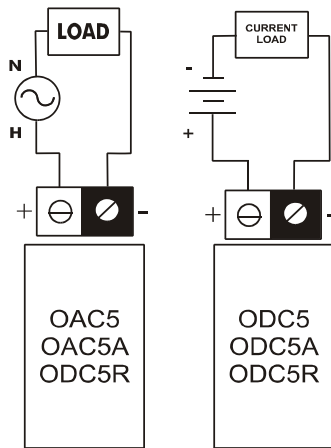

Figure 2-15 Digital Output Wiring

2 Pass	2 - 15, 2 - 17
4 Pass	2 - 15
Address	1 - 8, 2 - 17
Addresses	2 - 14
ANALOG INPUTS	1 - 2, 1 - 9, 2 - 20
ANALOG OUTPUTS	1 - 3, 1 - 9, 2 - 22
Analog/ Digital	2 - 14
Analog/digital	2 - 17
BASIC I/O Models	1 - 11
Baud rate	2 - 14
Baudrate	2 - 17
COMMUNICATION PROTOCOL	1 - 8
Communication verification	2 - 18
Communications protocol	2 - 3
Data throughput	1 - 6
Debugging	2 - 18
DIAGNOSTICS	1 - 10
DIGITAL INPUTS	1 - 4, 1 - 9
Digital Outputs	1 - 5, 1 - 9, 2 - 24
Error codes	2 - 19
Frequency	1 - 9
Fuses	2 - 19
Last Unit	2 - 16
Modules	1 - 9
MOUNTING	2 - 1
Multidrop	2 - 4, 2 - 7, 2 - 16
Network	2 - 9-2 - 12
Network bias resistors	2 - 8
Network Debugging	2 - 18
Network termination resistor	2 - 16
Network type switches	2 - 10, 2 - 11, 2 - 12
Noise suppression	2 - 8
Power	2 - 2
Power Requirements	1 - 10
PRODUCT TEST	1 - 11
PROTOCOL	1 - 8, 2 - 15
Repeat	2 - 4
Repeater	2 - 7, 2 - 16
RS-422	2 - 5, 2 - 9
RS-422	2 - 10
RS-485	2 - 5, 2 - 6, 2 - 11, 2 - 12
Sample rate	1 - 2
Serial communications	2 - 5
SYSTEM THROUGHPUT	1 - 6
Temperature	1 - 2, 1 - 9
Test	2 - 18
Thermocouple	1 - 2, 1 - 9
THROUGHPUT	1 - 6

July 2004
First Revision



BASIC I/O AD
Hardware
Users
Manual



6979 Wales Road
Northwood, Ohio 43619

Phone: 419-666-4700
Toll Free: 800-248-1632
Fax: 419-666-4702

E-Mail: info@dutec.net
<http://www.dutec.net>

Copyright:

Copyright 1995- duTec Inc. All rights reserved. However any part of this document may be reproduced, provided that DuTec Inc. is cited as the source. The contents of this manual and the specifications herein may change without notice.

Trademarks

The DuTec logo, and the **BASIC I/O AD** are trademarks of DuTec Inc.

Notice to the User

The information contained in this manual is believed to be correct. However DuTec Inc assumes no responsibility for any of the circuits described herein, conveys no license under any patent or other right and makes no representations that the circuits are free from patent infringement. DuTec Inc. makes no representation or warranty that such applications will be suitable for the use specified without further testing or modification.

duTec Inc. general policy does not recommend the use of its products in life support applications where failure or malfunction of a component may directly threaten life or injury. It is a condition of sale that the user of duTec Inc products in life support applications assumes all risk of such use and indemnifies duTec Inc. against all damage.

Warranty

duTec Inc. warrants its products to be free of defects in materials and workmanship for a period of two (2) years from the shipment date. DuTec Inc. , at its option will repair or replace all material found to be defective. All repair or replacement must be performed by duTec Inc. personnel. Any parts determined by duTec Inc.. To be defective as the result of abuse, attempts to repair, or misuse will be repaired at the expense of the customer. DuTec Inc. will not be liable for any consequential, incidental, or special damages.

Overview	1 - 1
Capacity	1 - 1
I/O signal compatibility	1 - 2
Diagnostics	1 - 2
Communications watchdogs	1 - 2
Easy setup	1 - 2
Protocol Compatibility	1 - 3
Available I/O functionality	1 - 4
Analog Input Functions	1 - 4
Analog outputs	1 - 4
Digital inputs	1 - 5
Digital outputs	1 - 5
Extended capabilities	1 - 6
Specifications	1 - 7
Communications	1 - 7
Power	1 - 7
Environment	1 - 7
Ordering Information	1 - 7
Options	1 - 7
Available I/O Modules	1 - 8
Installation	2 - 1
Mounting	2 - 1
Power Wiring	2 - 2
Designing the Network	2 - 3
Multidrop	2 - 3
Repeat	2 - 3
RS-422	2 - 4
RS-485	2 - 4
RS-485 Programming	2 - 5
Communication Wiring	2 - 6
Network load V.S. Noise suppression	2 - 7
Network bias resistors	2 - 7
Network Type Switches	2 - 8
Repeat	2 - 9
Multidrop	2 - 9
Last Unit	2 - 9
Communications Wiring	2 - 10
Host to BASIC I/O AD-RS	2 - 10

RS-485 Host to BASIC I/O AD	2 - 11
BASIC I/O AD TO BASIC I/O AD RS-422	2 - 12
BASIC I/O AD to BASIC I/O AD RS-485	2 - 13
Installing the I/O modules	2 - 14
Module Wiring	2 - 15
Analog Inputs	2 - 15
Analog outputs	2 - 17
Digital Inputs	2 - 18
Digital Outputs	2 - 19
Chassis Setup	2 - 1
Setup pushbutton	3 - 1
Sequential display	3 - 1
Baud rate	3 - 3
Protocol Handshake Types	3 - 3
Changing Setup Parameters	3 - 4
Communication Verification	3 - 5

Overview

BASIC I/O ADs are a family of small, industrial grade, remote data acquisition and control systems which exchange data with a Host computer via a serial communications link. Controlled by a wide range of software running on a Host computer, **BASIC I/O ADs** are located near the sensors and actuators. The serial link eliminates the need for expensive and noise prone signal wiring between field sensors and actuators, and a central control room.

In applications such as remote process monitoring, factory automation, and energy management, a variety of signals must be transmitter over long distances. Instead of requiring expensive, multi-conductor, sensor wiring for each signal, cabling costs can be reduced significantly by using **BASIC I/O ADs** and a single communications circuit.

One of the most useful features of the **BASIC I/O AD** is that in addition to gathering raw data, it can be instructed to perform many ranging and statistical operations upon the data before it is given to the host, thus allowing the host to spend less time manipulating data and more time gathering it. Also the **BASIC I/O AD** is able to spend more time exposed to the data which in turn allows it to base its responses to the host on more samples of data. The **BASIC I/O AD** may also be directed to manipulate outputs in specific ways to produce delayed or repetitive effects.

Capacity:

Each **BASIC I/O AD** system consists of one logic board connected to a 4, 8, or 16 position I/O module mounting rack. This combination is then field configurable to accept either analog or digital electrically isolated input or output modules which can interface to a wide variety of sensors and actuators.

BASIC I/O AD networks can service over 4000 analog and/or digital I/O lines in various combinations.

Product Test:

Every **BASIC I/O AD** is burned-in at 70°C while operating in a network for a period of 24 hours prior to shipment.

Every analog I/O module is operated and tested while it's ambient operating temperature is cycled over the specified operating range of 0°C to 60°C for a period of 24 hours. A computer record is generated for every analog I/O module.

I/O signal compatibility:

BASIC I/O ADs use duTec I/O modules to match signal requirements exactly. With a direct interface to sensors, no external signal conditioning is required. Furthermore, all duTec modules feature total electrical isolation, both module to logic and module to module. Analog modules are available to measure:

- Millivolts DC to hundreds of volts AC
- Milliamps DC to amps AC
- Frequency to tens of Khz
- Temperature with all popular thermocouples and restive temperature devices

A full range of industry standard digital modules are available for AC, DC, and dry contact inputs and outputs to hundreds of volts.

Thermocouple modules provide a cold reference junction compensation. **BASIC I/O AD** instructions provide linearized thermocouple and RTD sensor data. Engineering unit conversions are handled at the host lever.

Diagnostics:

To confirm internal operations and communications link integrity, a set of built-in diagnostics test key system functions each time power is applied. Diagnostics reduce both installation debugging and operation troubleshooting.

A hardware watchdog timer insures safe shutdown in the event of processor or software failures by turning all outputs OFF. Normally ON modules are available for those loads that must remain ON.

Communications watchdogs:

The **BASIC I/O AD** can be instructed to implement alarm and fail-safe states in the event of a communication failure.

Easy setup:

The **BASIC I/O AD** uses a pushbutton and an on board LED indicator to configure the unit address, analog VS digital map and baud rate.

Protocol Compatibility:

The **BASIC I/O AD** instruction set core complies 100% with that of the OPTO- 22 Optomux™ . With this ASCII character, speak-only-when-spoken-to protocol, a Host transmits inquiry requests to the **BASIC I/O AD** to determine the status of its various process inputs. Similarly, the software in the Host computer makes control decisions and transmits instructions to the **BASIC I/O AD**, which in turn, makes the proper changes to its various outputs. Both the Host and its communications link are essential elements in this data acquisition and process control scheme.

Originally the protocol only allowed for all analog or all digital I/O chassis. Depending on application requirements, each **BASIC I/O AD** can respond to up to three different function addresses. With their abbreviations they are:

MC Master Unit Control function address

MD Master Unit Digital I/O function address

MA Master Unit Analog I/O function address

It is this multiple function addressing capability of **BASIC I/O ADs** that allows them to utilize, without modification, software developed for competitive products. Similarly **BASIC I/O ADs** can operate simultaneously on the same network with these products.

Available I/O functionality:**Analog Input Functions**

Input value	Determines signal levels, with 12 bits resolution
Offsets	Input values can be software offset, with 12 bits resolution, over the module's specified range.
Gain/ Slope	The amplitude of input values can be software multiplied by factors ranging from 0.25 to 4.0.
Range Limits	The occurrence of input values falling out of user defined upper or lower limits can be flagged.
Minimums	The minimum level of input values can be captured.
Maximums	The maximum level of input values can be captured.
Averages	Can calculate average input amplitude for 1-65,535 samples.
Temperature	Can linearize in, °C, inputs from thermocouples and RTDs. Will also return temperature probe data.

Analog outputs

Level Value	Can set output levels, as a function of the module's full scale range, and are specified with 12 bits resolution.
Waveforms	can provide square, triangular, sawtooth, or ramp waveforms. Maximum and minimum amplitudes, as a fraction of the output module's full scale range, are specified with 12 bits resolution. Waveform periods are specified 0.1 to 6,553 Sec (109 Min). All waveforms are made up of at least ten segments.

Digital inputs

Read	Read the on or off of all inputs
Pulse widths	The duration of a single or total on/off time of consecutive pulses can be resolved to the nearest 0.00 seconds for a max total of 10.9 minutes, or 46.6 hours with multiplied resolution. Positive or negative edges initiate measurements. The time scale can be multiplied by a factor of 1-256 on a system wide basis.
Pulse counting	Pulses can be counted up to a total of 65,535. To be reliably counted, pulses must have minimum on and off times of 1 mSec. Thus the maximum counting rate for a 50% duty cycle squarewave with equal on and off times for a total of 2 mSec. Would be 500Hz.
Edge detection	Off to on and on to off transitions can be detected within 1 mSec. Of their occurrence. Action is only reported every 10mSec.

Note: The response time performance of digital input instructions can be limited by the delay in the input modules themselves which can have on plus off delays of up to 40 mSec.

Digital outputs

Set Outputs	Can set individual or multiple outputs on or off Modifiers
One Shot	Can generate on or off pulse durations of up to 655.35 seconds with a resolution of 0.01 seconds. Resolution can be further multiplied by a factor of 1-256 on a system wide basis.
Delayed	Can generate on or off pulse durations of up to 655.35 seconds with a resolution of 0.01 seconds. Resolution can be further multiplied by a factor of 1-256 on a system wide basis.

Squarewave

Can generate squarewaves with programmable On and Off periods. On and Off periods have a base range from 0.01 to 2.56 seconds. Resolution can be further multiplied by a factor of 1-256 on a system wide basis. Re-triggering is available.

Pulse Generator

Can generate 1-65,535, 50% duty cycle pulses whose equal on and off periods can range from 0.01 to 2.55 Sec. Resolution can be further multiplied by a factor of 1-256 On a system wide basis.

Extended capabilities:

In addition to operating under the control of a host, Option/L of the **BASIC I/O AD** has the ability to perform local control functions without the host. Local control functions (LCFs) can insure the continued safe operation of closed loop control should the host of its communication link fail. In addition, LCFs can substantially reduce Host computational load or communications traffic.

Once characterized, Local Control Function blocks enable the **BASIC I/O AD** to perform control tasks without the constant involvement of the host computer. After configuration and activation via the host instructions, LCFs take data from their input ports, perform computations and send the results to their outputs where they may drive output modules, or other **BASIC I/O AD** internal functions.

Utilizing the LCF's to perform simple logic tasks such as analog comparisons, summations, differences, sequence generating or state machine operations eliminates the need for programmable controllers or special purpose circuitry. This capability allows a more effective use of the host computer and its communication link because the LCFs handle the operation of the designated control function. In the meantime the host is only required to monitor over-all system status and generate the system displays and reports. This is particularly valuable for systems using modems for communications.

Specifications
Network Communications:

duTec supports two standards for transmitting serialized I/O data between the host computer and the **BASIC I/O ADs** at baud rates to 38,400.

Serial Link	Maximum Distance	
	Feet	Meters
RS-422 /485	5,000	1,524

Physical Characteristics:

Power	Supply	5Vdc@<5A
Environment	Temperature	0-60 C
	Humidity	95% Non-Condensing
Options	/L	Local Control Function (LCF)

Ordering Information

Specify duTec products by model number, e.g.,

BIO4AD	4 Position BASIC I/O AD
BIO8AD	8 Position BASIC I/O AD
BIO16AD	16 Position BASIC I/O AD

Options are specified by a series of suffixes to the model number, preceded by a slash for example:

BIO8AD/L

Available I/O Modules
ANALOG INPUTS, 12 BIT **ANALOG OUTPUTS, 12 BIT**

Frequency		Voltage	
IF10K-B	Input 300Hz-10KHz	OV1	Output 0-1V, self-sourcing
IF2.5K-L	Input 0-2.5KHz	OV5	Output 0-5V, self-sourcing
IF5K-1	Input 0-5KHz	OV10	Output 0-10V, self-sourcing
IF10K-L	Input 0-10KHz	Current	
Voltage		O1420	Output 4-20mA, self-sourcing To 275 Ohm load
IV25M	Input 0-25mV		
IV50M	Input 0-50mV	DIGITAL	INPUTS
IV100M	Input 0-100mV	AC	
IV1	Input 0-1V	IAC5	Input 90-140Vac
IV5	Input 0-5V	IAC5A	Input 180-280Vac
IV5B	Input Bipolar +/-5V	DC	
IV10	Input 0-10V	IDC5D	Input 3-32Vdc Fast, >500Hz
IV10B	Input Bipolar +/-10V	IDC5S *	Input Dry Contact Sense, Built-in Isolated Voltage Source
IVAC	Input 28-140Vac	IDC5NP	Input 10-32 Vdc, 15-32Vac Non-Polarized.
VAC-A	Input 56-280Vac		
Current		DIGITAL	OUTPUTS
I420	Input 4-20mAdc	AC	
IAC5	Input 0-5Aac	OAC5	Output 12-140Vac, 3.5A
Thermocouple		OAC5A	Output 24-280Vac, N.C.(Normally Closed)
TCE	Type E 0 To 435° C	OAC5J	Output 20-280Vac, 6.0A
TCJ	Type J 0 To 700° C	DC	
TCJ-1	Type J -80 To 750° C	ODC5	Output 5-60Vdc, 3.5A
TCK	Type K -100 To 924° C	ODC5A	Output 4-200Vdc, 1.0A
TCK-1	Type K -110 To 1250° C	ODC5R	Electro-Mechanical 0.5A Relay Form A, Normally)
TCR	Type R 0 To 960° C	IDC5Z*	Input +/-200mV, 0-10KHz Digital**
TCR-1	Type R 0 To 1760° C	SPS-1*	Sensor Power Supply 18-24 Vdc, 30mA
TCS	Type S 0 To 1034° C	FI01	Digital Input/ Output Test Module with Field Switch and LED
TCS-1	Type S 0 To 1760° C		
TCT	Type T -200 To 224° C		
TCT-1	Type T -120 To 400° C		
TCT-2	Type T 0 To 150° C		
SPECIAL PURPOSE		SUPPORT	PRODUCTS
RTD		Fuses	
TR10	10 Ohm Cu -55 To 150 °C	FM-06	Fuse assembly, 0.062A 100 mA for modules marked with an *
TR100	100 Ohm Pt -55 To 350 °C	FM-1	Fuse assembly, 1.0A
TR100-1	100 Ohm Pt 0 To 100 C	FM-3	Fuse assembly, 3.0A
Type 590 Temperature Sensor		FM-5	Fuse assembly, 5.0A
TP590	-188.4 To 150 °C		
TP590-1	-50.0 To 150 °C		

* When selecting a power supply for the system assume 25mA for standard digital modules and 100mA for modules marked with an *

** The IDC5Z module is used for low-level signals and will pass signals at the rate of 10kHz The **BASIC I/O AD** however, is limited by communications baudrate.

Installation

Mounting:

BASIC I/O ADs come in 4, 8, and 16 channel versions. Figure 2-1 below shows the footprint of each Basic I/O AD. Using corner holes, the unit can be mounted with 4- #6 or #8 round head or pan head screws. The BIO16 version has two additional mounting holes located near the center of the board as well. Hole locations in relation to the overall dimensions for each are shown below.

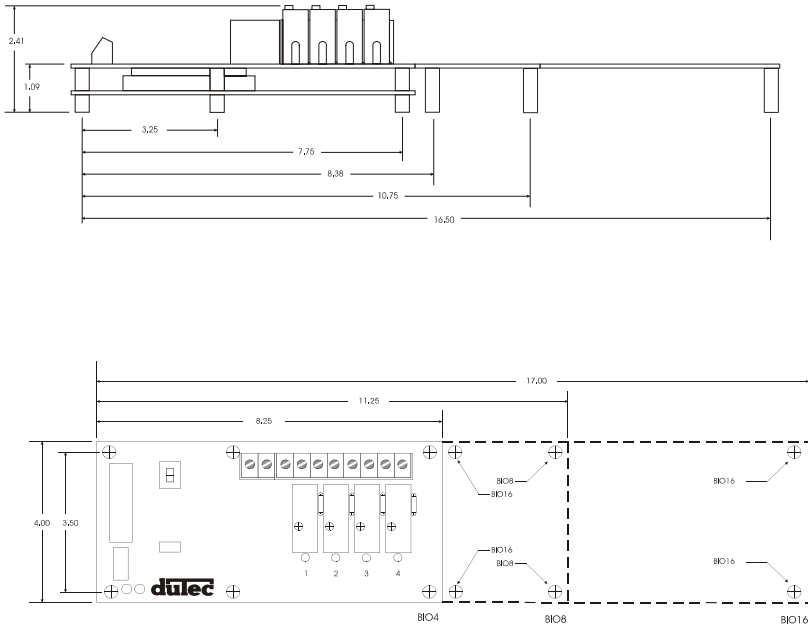

Figure 2-1 BASIC I/O AD Footprint

Power Wiring:

Power connections are made at the 2 position terminal block located on the module board marked +5V and GND No. 8 captive wire clamps accept 10-16 AWG wire or spade lugs.

Power wiring conventions:

- + of the power source to the terminal marked +5V
- of the power source to the terminal marked GND

Power requirements

Voltage: 5.0- 5.4Vdc

Current: 250 mA + 25mA per digital module and 200mA per analog module.

Practices: In general it is good practice to reserve the +5Vdc power supply exclusively for the task of powering one or more **BASIC I/O ADs**. As with any microprocessor based equipment, reasonably clean power is required for reliable operation. Sharing power with other devices such as field signal transducers and contact excitation should be avoided

Designing the Network

In order for the **BASIC I/O AD** to share its data with the host computer, it must be linked via a serial connection. This link can be hard-wired using an RS-422 dual twisted pair or an RS-485 single twisted pair connection where the wire run between devices is less than 5000 feet. In any event, the appropriate transmitter of the **BASIC I/O AD** will be connected to a suitable receiver of the host computer. Multiple **BASIC I/O AD** chassis can be networked together to service large numbers of I/O points. These serial connections can be either multidrop or repeat.

Multidrop:

Multidrop networks can be up to 5000 ft long end-to-end.

Each station is passively located on the network and represents one “Drop” or load to the host communication driver.

A multidrop network will tolerate loss of power to any one station without effecting the rest of the network.

RS-485 can only be multidrop

Signal boost may be necessary depending on line conditions and number of drops.

Repeat:

Repeat networks can be as long as 5000 ft between each unit.

Each station plays an active role in communications to other units. If power is removed from a unit in a repeat network, communications to units “downstream” from it will be lost as well.

RS-422:

- Advantages:
- Easier to implement in software since host driver need not be controlled.
 - Can be either Multidrop or Repeat.
 - No turn-around delay required.

Disadvantages: Requires five conductor wire instead of three.

RS-485:

Advantages: Needs only 3 wire conductor.

- Disadvantages:
- Host 485 driver control must be implemented requiring tricky serial port manipulations.
 - Can only be Multidrop.
 - Usually requires turn around delay implementation.

RS-485 Programming:

The **BASIC I/O AD** will work equally well when connected as RS-422 or RS-485. However special host programming considerations may be necessary when implementing an RS-485 network. Unlike RS-422 where both the *transmit and Receive* signals have their own differential pair of conductors, RS-485 utilizes only one differential pair. The single pair of conductors is used bidirectionally and handles both *transmit and receive* signals. In order for this to be possible, the transmitter for each device on this type of network must be enabled and disabled whenever a message is to be sent. The transmitter for the **BASIC I/O AD** is designed to handle this control automatically, the transmitter control for most popular RS-485 cards that are installed in the Host computer must be controlled by the user program. This control is not straight forward and may impact the overall system throughput with inherent delay periods. The following is a typical instruction/ response transaction between a host computer and a **BASIC I/O AD** using **RS-485**.

- 1) The Host computer enables its RS-485 transmitter (usually via the RTS line)
- 2) The Host then sends an instruction to the **BASIC I/O AD** in the form of an ASCII printable string.
- 3) Once the Host determines that the string has been completely sent, the RS-485 transmitter is disabled.
- 4) Every **BASIC I/O AD** on the network receives the instruction and begin to decode it. That particular **BASIC I/O AD** addressed begins to construct a response.
- 5) Once the carriage return is of the instruction is received, then begins to transmit a response.
- 6) The Host receives the response and takes the appropriate action.

This interaction is heavily dependant on asynchronous timing. Usually, the Host software has no real means of determining that the instruction has been completely sent. This means that the program must calculate the approximate time necessary to transmit the entire instruction before the RS-485 driver is disabled. Since the **BASIC I/O AD** can respond very quickly to the instruction, the Host must disable the driver as soon as possible in order to receive the **BASIC I/O ADs** response. RS-485 communications can be tricky at best and should be seriously considered before being adopted. Third party software users should make sure that the package they have chosen supports the particular RS-485 communications card to be used.

Communication Wiring:

The Host to first **BASIC I/O AD** can be RS-422 or RS-485. Most Host computers come equipped with an RS-232 serial port. A choice must be made to either equip the host with an RS-422 or RS-485 card or to use an external RS-232 to RS-422/ 485 converter such as the duTec BaudMASTER.

For ranges less than 5000 feet, both RS-422 and RS-485 networks can operate in multidrop mode. For ranges greater than 5000 feet, RS-422 (NOT RS-485) networks can operate in repeater mode. In this mode, the distance between individual units can be up to 5000 feet. The trade-off for using the repeat mode is that the powering down of any single unit disables communications with all units further “downstream” from the host.

A network of **BASIC I/O AD** must be made up of units which are configured as either all multidrop or all repeat.

Network load V.S. Noise suppression:

In order to improve RS-485 Bus noise immunity, particularly under tri-state conditions, a pair of “Network Bias Resistors” have been installed in each **BASIC I/O AD** unit. This design feature has been implemented in order to satisfy the majority of our customers. If it is necessary to multidrop more than eight **BASIC I/O AD** units (but ultimately less than thirty-two devices), it will be necessary to remove these network bias resistors so as to not exceed the maximum bus loading. However, in order to retain noise immunity, the network bias resistors should remain installed in at least one **BASIC I/O AD** on the network. Figure 2-4 below shows the location of the four network bias resistors.

R34 is the 1.5k from prior +bias resistor
R35 is the 1.5k from prior - bias resistor
R36 is the 1.5k from next + bias resistor
R37 is the 1.5k from next - bias resistor

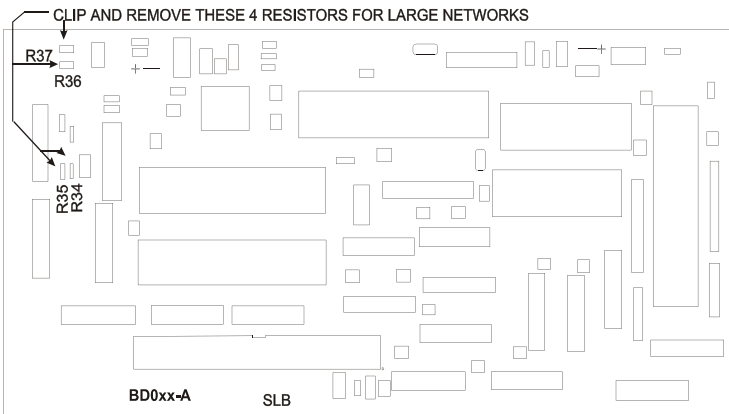

Figure 2-2 Network Bias resistor locations

Network Type Switches

Based upon the selected network configuration, each **BASIC I/O AD** *must* be setup before communications can begin. This is done with the network switches shown in figure 2-3.

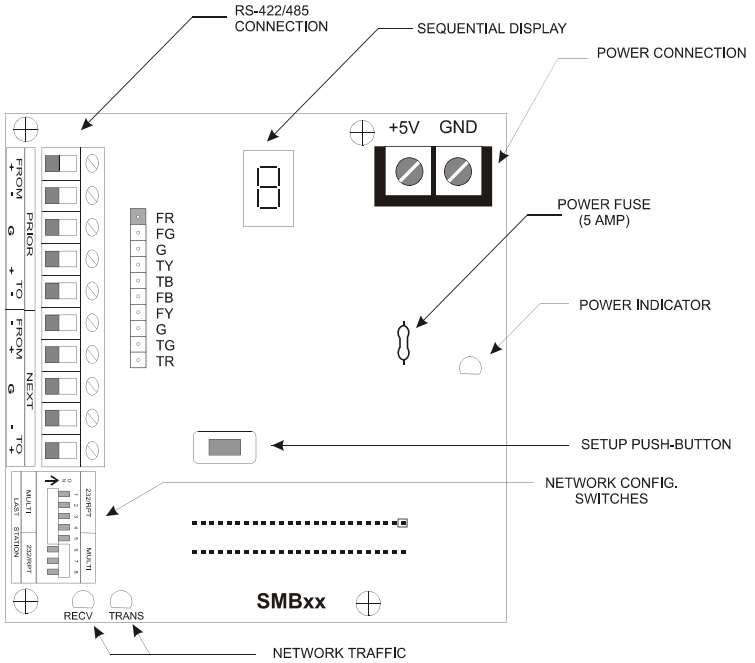
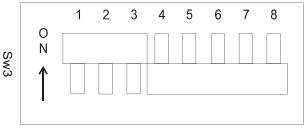
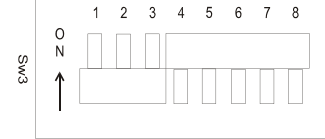
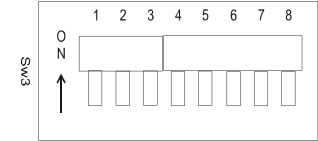

Figure 2-3 BASIC I/O AD Connectors, Switches and Indicators.

The three basic communication connections for individual **BASIC I/O ADs** are:

<p>Repeat Used in RS-422 networks to extend range to 5000 feet between units. Sequential Display reads L1</p>	 <p>The diagram shows a horizontal row of 8 numbered positions (1-8). Above the row, positions 1, 2, and 3 are connected to a single horizontal bar. Above positions 4, 5, 6, 7, and 8 are individual vertical bars. Below the row, positions 1, 2, and 3 have individual vertical bars, while positions 4 through 8 are connected to a single horizontal bar. To the left of the row, there are three labels: 'O', 'N', and 'S', with an upward-pointing arrow below them. The label 'SWS' is positioned to the left of the arrow.</p>
<p>Multidrop Used in RS-422 or RS-485 networks. Provides a total network range of 5000 feet. Display reads L2</p>	 <p>The diagram shows a horizontal row of 8 numbered positions (1-8). Above the row, positions 1, 2, and 3 have individual vertical bars, while positions 4 through 8 are connected to a single horizontal bar. Below the row, positions 1 through 3 are connected to a single horizontal bar, while positions 4 through 8 have individual vertical bars. To the left of the row, there are three labels: 'O', 'N', and 'S', with an upward-pointing arrow below them. The label 'SWS' is positioned to the left of the arrow.</p>
<p>Last Unit Must be used in RS-422 and RS-485 networks for the unit most distant from the host. Sequential display reads L3</p>	 <p>The diagram shows a horizontal row of 8 numbered positions (1-8). Above the row, positions 1 through 3 are connected to a single horizontal bar, while positions 4 through 8 are connected to another single horizontal bar. Below the row, positions 1 through 3 have individual vertical bars, while positions 4 through 8 are connected to a single horizontal bar. To the left of the row, there are three labels: 'O', 'N', and 'S', with an upward-pointing arrow below them. The label 'SWS' is positioned to the left of the arrow.</p>

If there is only one **BASIC I/O AD** in a network it is designated L3.

For the network layout, the sequential display indicates the letter "L" followed by "1", "2", or "3". As shipped, **BASIC I/O ADs** are setup as "L3", Last Unit. This parameter is not changed by push button but is displayed as "L1", "L2", or "L3" after the dip switches have been set and the unit has undergone a power cycle.

Communications Wiring

Host to **BASIC I/O AD-RS-422**:

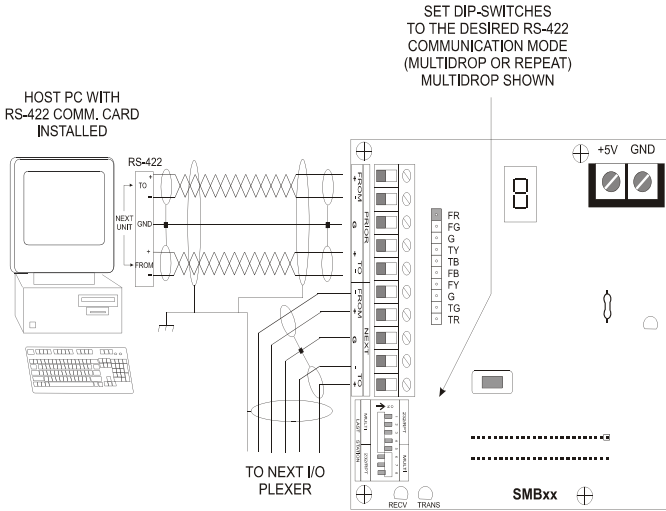

Figure 2-7 RS-422 Host to BASIC I/O AD

Figure 2-7 shows two individually shielded twisted pairs of AWG 24. Each pair has a ground wire connected to its shield. These drain wires are then connected to the signal grounds at each unit. A Separate shield encases the entire cable. The drain wire for this over-all shield is tied to earth ground at one location. An example of acceptable wire for this application would be Belden 8162. In a perfect world with no electrical noise and equal ground potentials everywhere, the ground connection is not required. However, omitting this signal ground in industrial applications can lead to costly debugging.

These connections are made by placing a 1/4 inch stripped wire into the openings of the wire clamp terminal block and tightening the screw. This terminal block will accept gauges from 14 to 30AWG. An alternate means for network connection is to use the 10 pin male connector located behind the clamp terminal block. This connector mates with Molex shell number 50-57-9005, and uses pins number 16-02-0103.

In addition to the Host-To-BASIC I/O AD wiring, the installer should confirm that the network type switches are set in the correct position: Multidrop, Repeater, or Last Unit.

BASIC I/O AD TO BASIC I/O AD RS-422**Figure 2-6 RS-422 BASIC I/O AD-To-BASIC I/O AD**

Figure 2-6 shows one individually shielded twisted pair of AWG 24. Each pair has a drain wire connected to its shield. These drain wires are then connected to the signal grounds at each unit. A separate shield encases the entire cable. The drain wire for the over-all shield is tied to earth ground at one end. An example of acceptable wire for this application would be Belden 8162. In a perfect world with no electrical noise and equal ground potentials everywhere, the ground connection is not required. Omitting this signal ground in industrial applications can lead to unstable operation and costly debugging

These connections are made by placing a 1/4 inch stripped wire into the openings of the wire clamp terminal block and tightening the screw. This terminal block will accept gauges from 14 to 30 AWG. An alternate means of network connection is to use the ten pin male connector located behind the clamp terminal block. This connector mates with Molex shell number 50-57-9005, and uses pins 16-02-0103.

In addition to the **BASIC I/O AD to BASIC I/O AD** wiring, the installer should confirm that the network type switches are set in their correct position: Multidrop, Repeater, or Last unit.

BASIC I/O AD to BASIC I/O AD RS-485

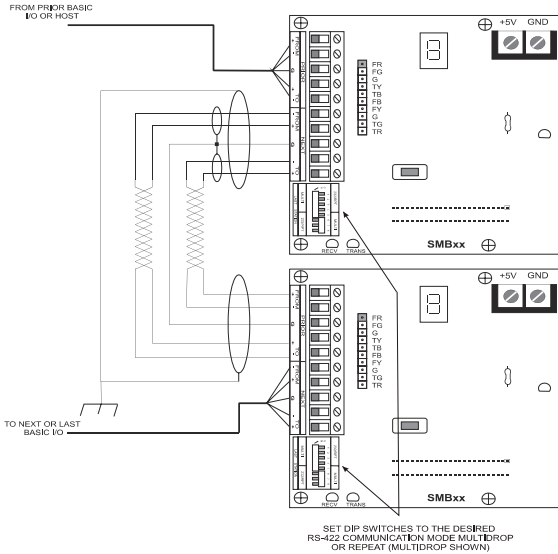
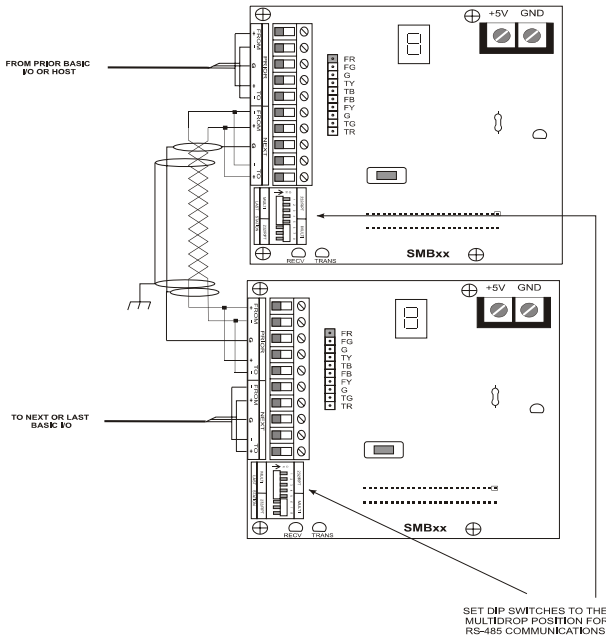

Figure 2-8 RS-485 BASIC I/O AD to BASIC I/O AD

Figure 2.8 shows one individually shielded twisted pair of AWG 24. Each pair has a ground wire connected to its shield. These drain wires are then connected to the signal grounds at each unit. A Separate shield encases the entire cable. The drain wire for this over-all shield is tied to earth ground at one location. In a perfect world with no electrical noise and equal ground potentials everywhere, the ground connection is not required. However, omitting this signal ground in industrial applications can lead to costly debugging.

These connections are made by placing a 1/4 inch stripped wire into the openings of the wire clamp terminal block and tightening the screw. This terminal block will accept gauges from 14 to 30AWG

An alternate means for network connection is to use the 10 pin male connector located behind the clamp terminal block. This connector mates with Molex shell number 50-57-9005, and uses pins number 16-02-0103.

In addition to the **BASIC I/O-To-BASIC I/O AD** wiring, the installer should confirm that the network type switches are set in the correct position: Multidrop, Repeater, or Last Unit.

Installing the I/O modules:

Certain guidelines must be followed when installing I/O modules on the **BASIC I/O AD** Chassis. In particular the analog modules must be grouped separately from the digital modules on each I/O chassis. Using the worksheets found on the next page, place the desired I/O modules in the indicated positions.

BASIC I/O AD Module Placement Worksheet

Module#	Analog/Digital	Module PN	Remarks
1			
2			
3			
4			
5			
6			
7			
8			
9			
10			
11			
12			
13			
14			
15			

- 1) Install all analog input modules beginning with module 0 the 1 and so on. If none are used, skip this step.
- 2) Install Analog output modules beginning with the next available module position. If none are used, skip this step.
- 3) Repeat step 2 for the digital input and digital output modules

Module Wiring

Analog Inputs:

Modules should **NEVER** Be installed or removed while power is applied to the **BASIC I/O AD**. Following insertion in their respective sockets, modules should be secured with the captive screw.

Note: Analog Modules Normally Run hot to the touch

Correct polarity connections are essential to proper operation of all the analog inputs. Connections to terminals marked with a + must be more positive than the terminals marked with a -. Thermocouples and RTDs are connected directly to modules with special connectors which insure correct polarity.

Analog input module status indicators are On dimly, when input modules are installed, wired correctly, and their input signal is within the module's valid range. If these conditions are not met, the in the touchght may be on brightly, off or may flicker.

Figure 2-11, figure 2-12, and figure 2-13 show the wiring for various types of analog inputs. With the exception of thermocouples and RTD modules, connections are made via the black terminal strip. In the case of thermocouples and RTDs mating connectors are included. There must be nothing connected to the screw terminals corresponding to these module positions. The source of analog input voltage or current is external to the **BASIC I/O AD** with the exception of ITP590, ITR10, ITR100, and ITR100-1.

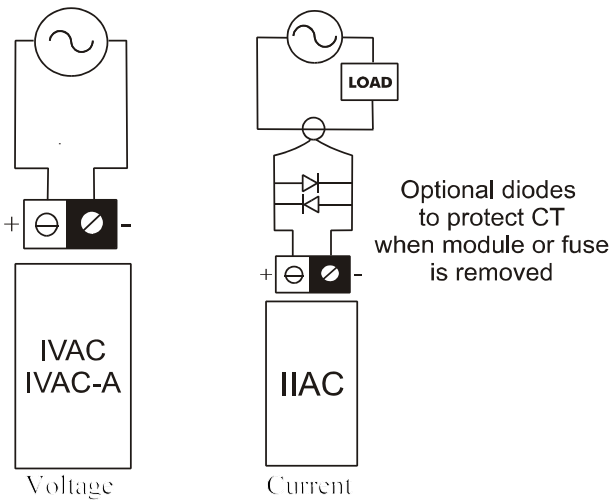

Figure 2-11 AC current and voltage wiring

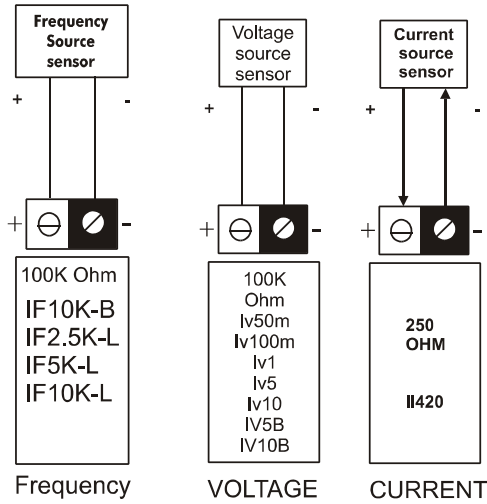

Figure 2-12 Analog Voltage, frequency and Current input Wiring

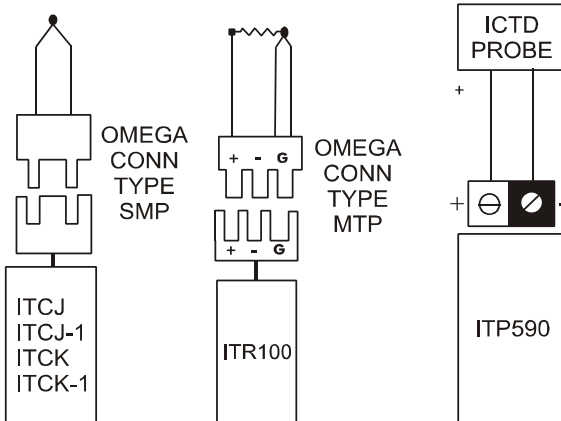

Figure 2-13 Temperature Input Wiring

Analog outputs:

Modules should **NEVER** be installed or removed while power is applied to the **BASIC I/O AD**.

Note: Analog modules run hot to the touch.

Both voltage and current output modules provide their own isolated power output. This eliminates the need for external power supplies and insures electrical isolation between each output. This also makes it possible to wire voltage outputs in series to obtain larger voltage swings.

Module status indicators for analog outputs blink briefly as outputs are updated. It should be noted that the status indicator only follows the logic instruction to the modules and does not indicate the output status. Outputs can only be verified by observing the output device or by a multimeter or oscilloscope measurement.

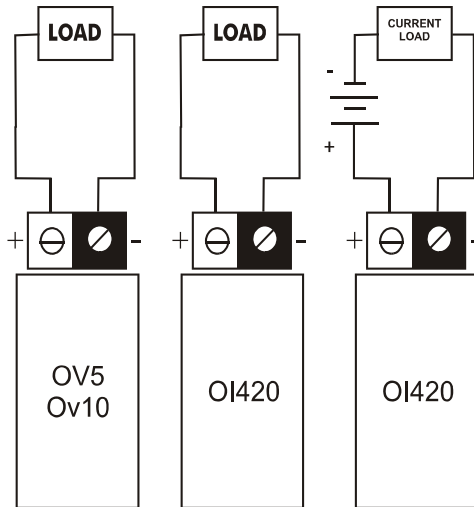

Figure 2-14 Analog Voltage and Current Output Wiring

OI420 analog output modules provide the current into loops with total resistance less than 275 ohms. If the loop resistance exceeds 275 ohms, an external power supply must be added to the loop as shown in figure 2-13 correct polarity is essential.

Digital Inputs:

Modules should never be installed while power is applied to the **BASIC I/O AD**.

With the exception of IDC5S digital input modules, input sensing current comes from a source external to the **BASIC I/O AD**. IDC5S input modules provide their own current for sensing contact closures. They can be **DESTROYED** if an external source is used.

The IDC5 and IDC5D input modules are polarity sensitive and operate only when the + terminal is more positive with respect to the - terminal. Polarity does not affect the performance of the IAC5, IAC5A, or the IDC5S input modules.

Because the field side of input modules are totally isolated from each other, like polarities can be wired common to make use of a single power supply.

The wiring and operation of digital input modules can be verified by closing the individual input sensing contacts and observing the changes on the module status indicators. They are on when the module circuit is energized.

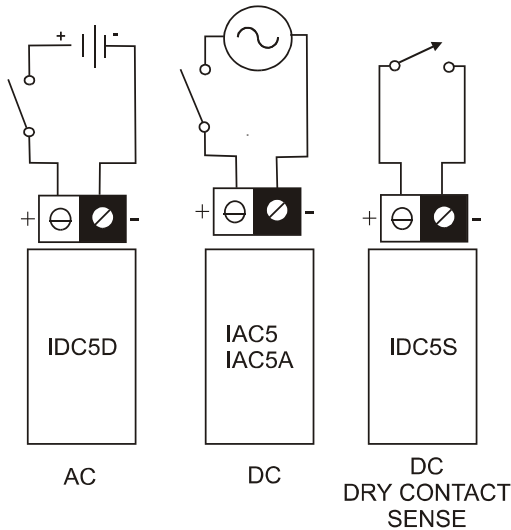

Figure 2-15 Digital Input Wiring

Digital Outputs:

Modules should NEVER be installed or removed while power is applied to the **BASIC I/O AD**.

The power for ODC5, ODC5A, OAC5, and OAC5A digital output modules comes from a source external to the **BASIC I/O AD**.

Because they contain a protective reverse diode, the ODC5 and ODC5A output modules are polarity sensitive and operate correctly only when the + terminal is positive with respect to the - terminal. A DC digital output module connected backwards conducts current through its protective diode and therefore cannot be controlled. Polarity does not affect the performance of the OAC5 and OAC5A Digital output modules.

Because the field sides of output modules are totally isolated from each other, like polarities can be wired common to make use of a single power supply.

The module status indicator should follow the instruction. It should be noted that the status indicator only follows the logic instruction to the modules and does not show that the module, its fuse, or that external power is present. Outputs can only be verified by observing the device or by a multimeter or oscilloscope measurement.

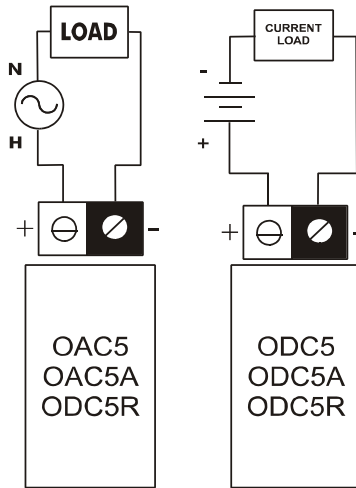

Figure 2-16 Digital output wiring

Chassis Setup

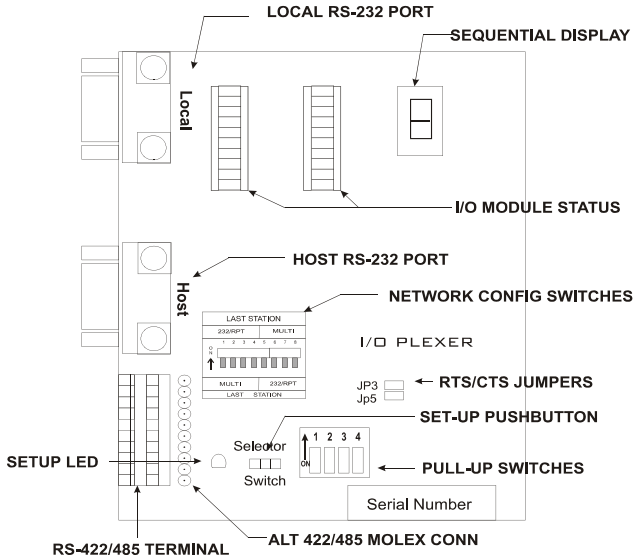

Figure 3-17 Connectors, Switches, and Indicators

During the setup phase of a **BASIC I/O AD** system, the chassis is given specific values for unit address, analog/ digital separator, network baud rate, and protocol pass type. A momentary pushbutton and seven segment display provide access to these parameters. Figure 3-17 shows the location of these components labeled setup pushbutton and sequential display.

Function addresses:

Each host instruction includes an address made up of two hexadecimal characters (00h-FFh). At any **BASIC I/O AD** network connection 3 different types of functions can be performed, each with its own unique system -wide function address. There are two **BASIC I/O AD** addressing modes, **offset** and **variable**.

Offset Mode

Units are shipped in the offset mode where only master init control address needs be set (with a range of 00h-3Fh). The remaining function addresses are automatically calculated and set based on master address.

Function	Abbrev.	Function Address	Sequential Display
Master Unit Control	MC	00h (0)	U0=00
Master Unit Digital I/O	MD	40h (64)	U1=40
Master Unit Analog I/O	MA	80h (128)	U2=80

The OFFSET addressing mode is more convenient to use as only one address setup is required for each network connection. For example changing the master unit control MC, from 00h to 03h will automatically cause MD=43h; MA=83h.

Variable Mode

In the variable mode function addresses are independent of each other and can range from 00h to Ffh. For this mode, each function, MC, MD, and MA must be entered. As long as addresses are not duplicated, they can take on any of the 256 possibilities. The variable mode must be used with some software packages and systems of more than 64 **BASIC I/O AD** network connections.

The loading of selected function addresses into the **BASIC I/O AD** is explained after the description of analog / digital separator, baud rates, and protocol handshake type.

Analog/ Digital separator:

Each **BASIC I/O AD** will require an analog/ digital separator to be set. This identifies which modules are analog and which are digital. This is necessary so that the system can properly direct each instruction to the appropriate module.

The analog/ digital separator is the character following the □ in the sequential display. It should be set equal to the HEX value of the lowest numbered module position containing a digital module (input or output). If this **BASIC I/O AD** contains only analog modules, set this value to G. Refer to the worksheet .

Baud Rates:

Any *One* of the standard baud rates of 300, 600, 1200, 2400, 4800, 9600, 19200, or 38400 can be used for the serial network communications. The sequential display indicates the letter H followed by the baud rate divided by 100. Basic I/Os are shipped at 9600 baud; the sequential display indicates H096. Changing the **BASIC I/O AD** baud rate is explained beginning on page 3-4

Protocol Handshake Types:

Two protocol handshake types are available, 2 pass and 4 pass.

- 2 Pass: The host transmits an instruction to a **BASIC I/O AD**. If the instruction is correctly received (i.e. valid address, instruction type and correct checksum) the **BASIC I/O AD** executes the instruction and returns the letter "A" and a cr or, where data is to be returned, the letter "A", then the data, followed by a two character checksum ending with a CR.
- 4 Pass: The host transmits an instruction to a **BASIC I/O AD**. If the instruction is correctly received (i.e. valid address, but not necessarily the correct instruction type nor checksum), the **BASIC I/O AD** returns an "A" followed by the Echo of the instruction and does *not* execute it. If the host then transmits an E, the instruction is executed in the same manner as the 2 pass. If the Hos transmits *any* other character to *any* unit on the network, the instruction is disregarded

The sequential display indicates the letter P followed by 2 or 4. **BASIC I/O ADs** are shipped in 2 pass mode; the sequential display indicates P2. The actual setting of the handshake protocol type is detailed following network type switch.

Network Type Switch:

The digit after the "1" ion the sequential display represents how the network switch is set.

Note: The seven segment display will not reflect a switch position change until power has been cycled to the unit.

Changing Setup Parameters Via Pushbutton:

During setup the user may need to change the unit address, serial link, baud rate, and protocol pass type. The pushbutton located under the removable cover is used to change these parameters. The pushbutton causes the adjacent red LED to flash each time it is pushed. Any changed values are automatically saved in non-volatile EEPROM.

During the diagnostic test period following the application of power, the sequential display shows "GoGoGo=" Flashing the pushbutton LED once when the = appears, places the unit in setup mode. The value of each setup character can be changed, as they appear in sequence, by pressing the pushbutton. The display will continue to cycle through the setup sequence until there is a full cycle with no changes. The **BASIC I/O AD** then stores all values in EEPROM for automatic use following each power cycle. If desired changes were not implemented correctly, line power can be cycled and setup via pushbutton procedure can begin again.

Once the unit has been placed in setup mode, as described above, the value of each setup character shown below, can be changed.

U 00□ 8H096P2 Only underlined digits may be changed.

The 2 digits after U0 indicate the master unit control address; initially set for address 00H-00.

Note: In the address offset mode, only one master address is set, the other addresses are automatically set 40H above each other

The digit after the □ indicates the analog/ digital separator.

The 3 digits after H show the baud rate divided by 100, initially set for 9600 baud. -096

The 1 digit after P signifies the handshake protocol type, initially set for 2 pass -2

The display continues to cycle through this sequence until there is a full cycle with no changes. The **BASIC I/O AD** then stores all values in EEPROM for automatic use following the next power cycle.

The unit is now in the operational mode and the sequential display cycle becomes*:

U0=00

U1=40

U2=80

□8

H012

L3

P2

Address Setup Via Network -Variable mode only

Each function address, including the master control address, of the **BASIC I/O AD** can be set individually by issuing a special instruction to the current master control address of that chassis. This “set variable address” instruction should be used with caution as it will change the unit address and save them in EEPROM. Consult the **BASIC I/O AD** protocol manual for details.

In the event that the new addresses become lost they will appear on the sequential display.

The pushbutton method can always be used to return to the offset mode.

Communication Verification:

Most startup problems are related to the communications link. The left network traffic LED (marked RECV). Blinks when there is serial data traffic being sent to this **BASIC I/O AD** from the host computer. The LED merely indicates serial data. It does not indicate that this data is valid nor at the proper baud rate. The right network traffic LED (marked TRANS) blinks each time this **BASIC I/O AD** sends data to the Host computer.

***factor default values for an IOP-AD/3+depicted in this example.**

Hardware error codes:

When the **BASIC I/O AD** is initially turned on it goes through internal self testing. If anything is not correct, the appropriate error code will flash on the sequential display. Try cycling power, if that does not resolve the error condition please call duTec technical support at 800-248-1632.

Analog Inputs	1 - 8, 2 - 15
Analog outputs	1 - 8, 2 - 17
Baud rate	3 - 3
Cabling costs	1 - 1
Chassis Setup	2 - 1
Communications	1 - 7
Communications watchdogs	1 - 2
Digital Inputs	1-8, 2 - 18
Digital Outputs	1-8, 2 - 19
Environment	1 - 7
Frequency	1 - 8
Isolation	1 - 2
Modules	1 - 8
Mounting	2 - 1
Multidrop	2 - 3, 2 - 6
Network Bias Resistors	2 - 7
Network Type Switch	3 - 3
Noise suppression	2 - 7
Power	1 - 7
Power Requirements	1 - 8
Power Wiring	2 - 2
Repeat	2 - 3
Repeater	2 - 6
RS-422	1 - 7, 2 - 3, 2 - 4
RS-485	2 - 4, 2 - 5
RTD	2 - 15
Sequential display	3 - 1
Setup	3 - 4
Setup pushbutton	3 - 1
Signal conditioning	1 - 2
Switches	2 - 12, 2 - 13
Temperature	1 - 8
Thermocouple	1 - 8, 2 - 15

